



## HIGHLIGHTS

- Good signage
- Close freeway access
- Lots of on-Site Parking
- New parking lot
- Brick building
- Close to several popular restaurants

9212 E. Montgomery  
Spokane Valley, WA  
AVAILABLE SUITES

Suite: 501: 1,115 sq.ft.  
\$1,200.00 per month  
plus NNN

Suite: 502: 940 sq.ft.  
\$1,075 per month  
plus NNN



# FOR LEASE

Levi McCormick:  
O: 509.462.9306  
levi@sdsrealty.com

Carlos Herrera  
C: 509.714.2593  
carlos@sdsrealty.com

## Suite 501

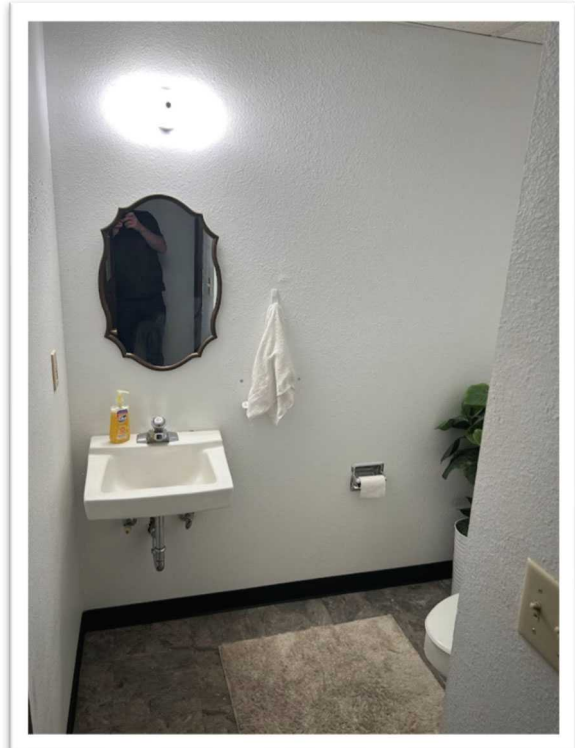
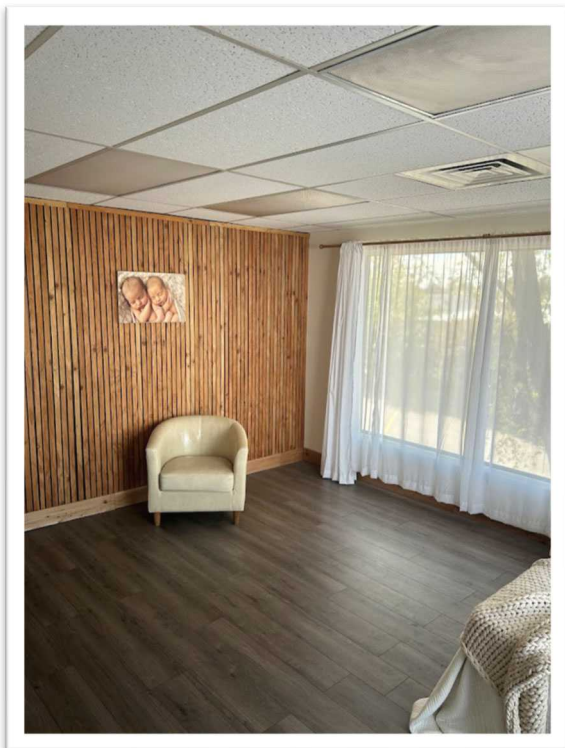
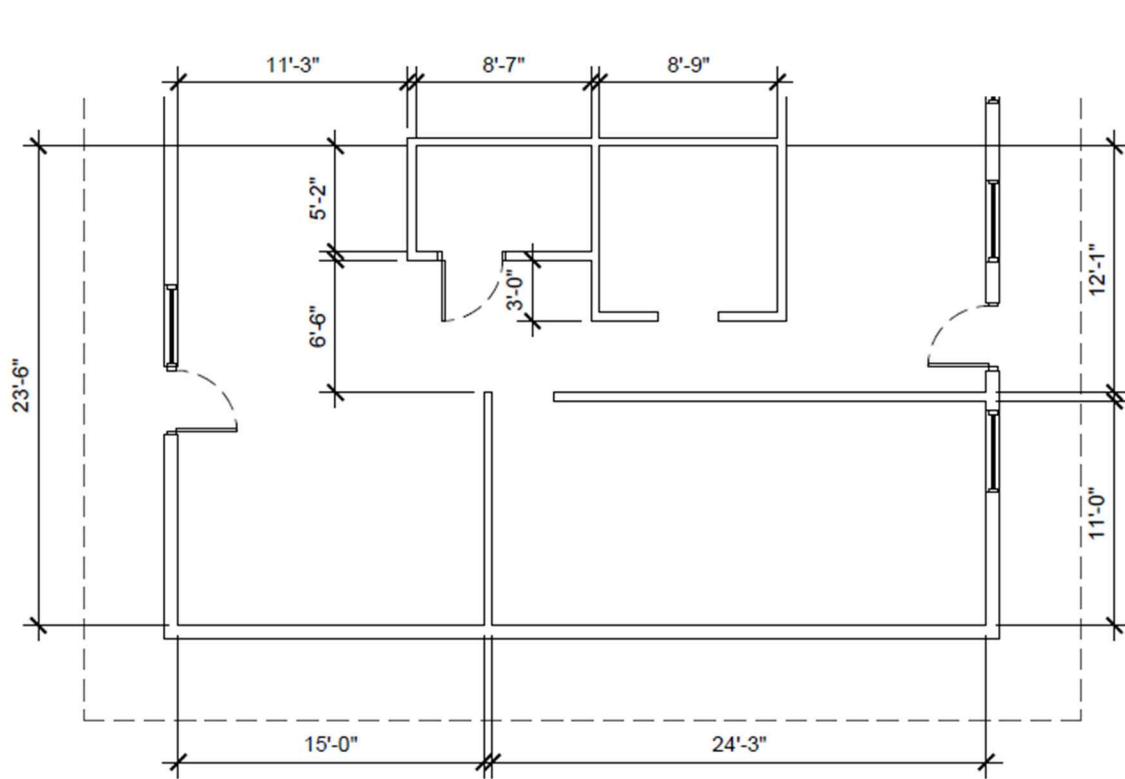



# FOR LEASE

Levi McCormick:  
O: 509.462.9306  
levi@sdsrealty.com

Carlos Herrera  
C: 509.714.2593  
carlos@sdsrealty.com

## Suite 502

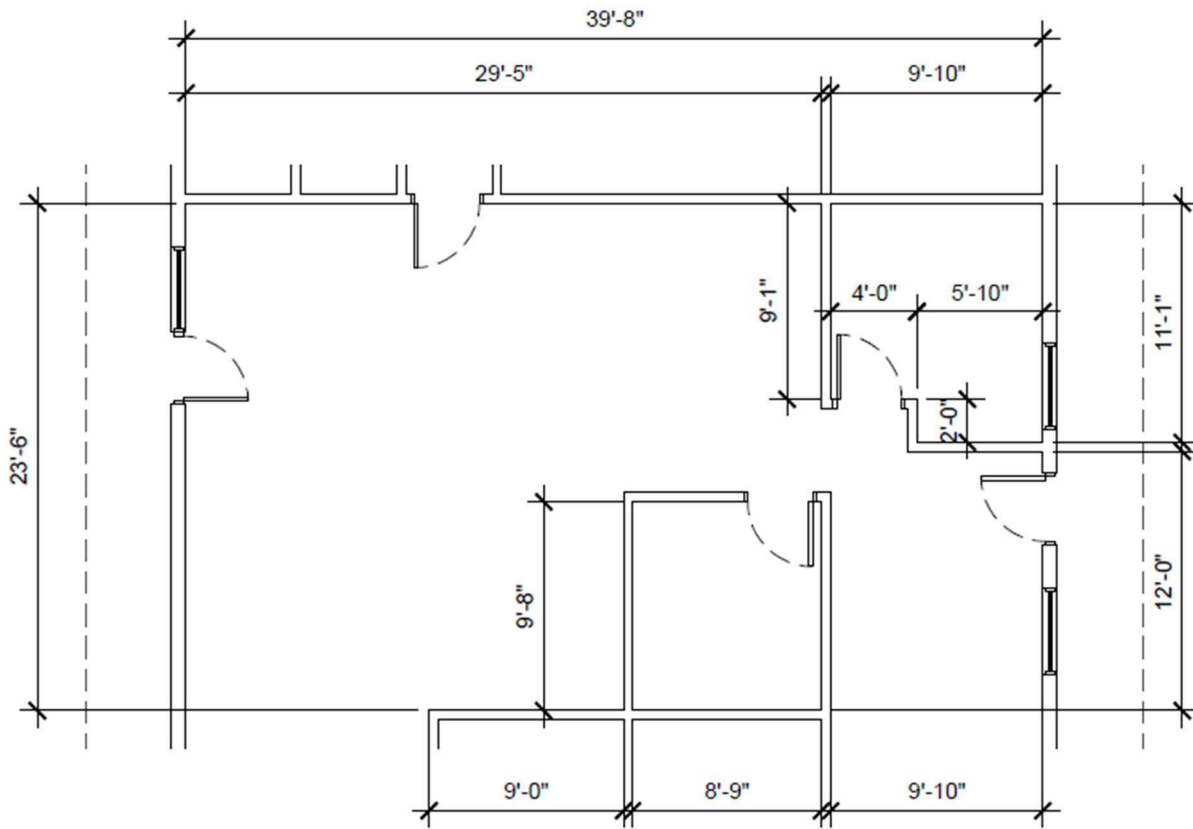

12 (010 SOFT)