



SPACE FOR LEASE

GARDEN COURT OFFICE SUITES

Total Building Size: ± 17,300 SF
Available Space: ± 276 SF up to ± 2,093 SF
Lease Rate: \$16.00 PSF
Building Conference Room
Building Breakroom
Free Parking (4/1,000)

AVAILABLE SPACE

SUITE #	SPACE SIZE	MONTHLY RENT	AVAILABILITY
30	± 2,093 RSF	\$2,791 / Month	NOW
224	± 1,448 RSF	\$1,810 / Month	NOW
230	± 552 RSF	\$736 / Month	NOW
250	± 907 RSF	\$1,209 / Month	NOW



Office space leased here helps support Hutton Settlement Children's Home, a historic not-for-profit organization dedicated to providing a safe and loving home for children.

www.huttonsettlement.org

KIEMLEHAGOOD.COM

Garden Court Building

222 W. Mission Avenue
Spokane, WA 99201

[View
Location](#)



CHRISTIAN ALFARO, BROKER

509.755.7505 christian.alfaro@kiemlehagood.com

TONY KING, PROPERTY MANAGER

509.755.7517 tony.king@kiemlehagood.com

**KIEMLE
HAGOOD**

FLOOR PLANS

SUITE 30

Price:

\$2,791 / Month

Space Size:

± 2,093 SF

AVAILABLE NOW

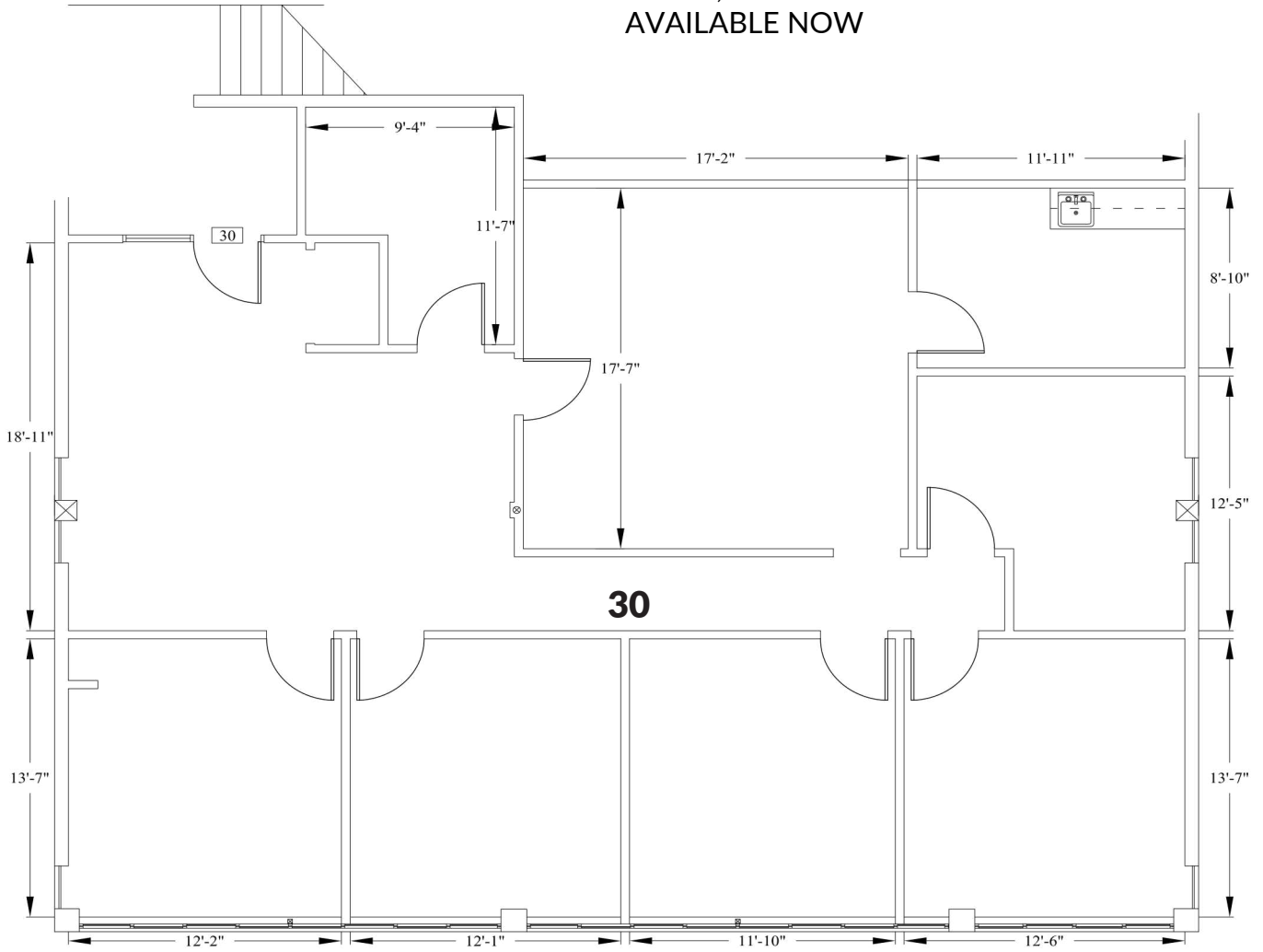

FLOOR PLANS

SUITE 224

Price:
\$1,810 / Month
Space Size:
± 1,448 SF
AVAILABLE NOW

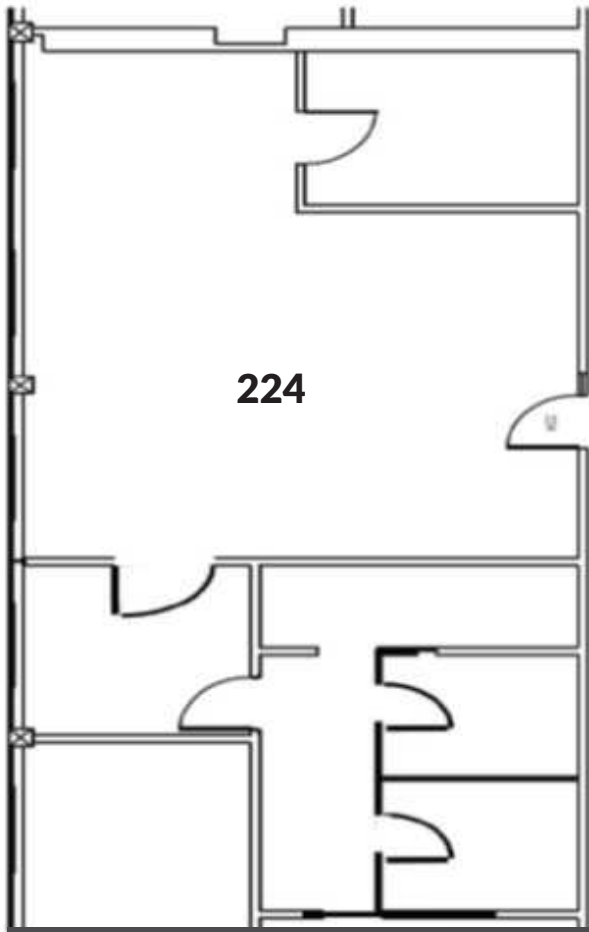

SUITE 230

Price:
\$736 / Month
Space Size:
± 552 SF
AVAILABLE NOW

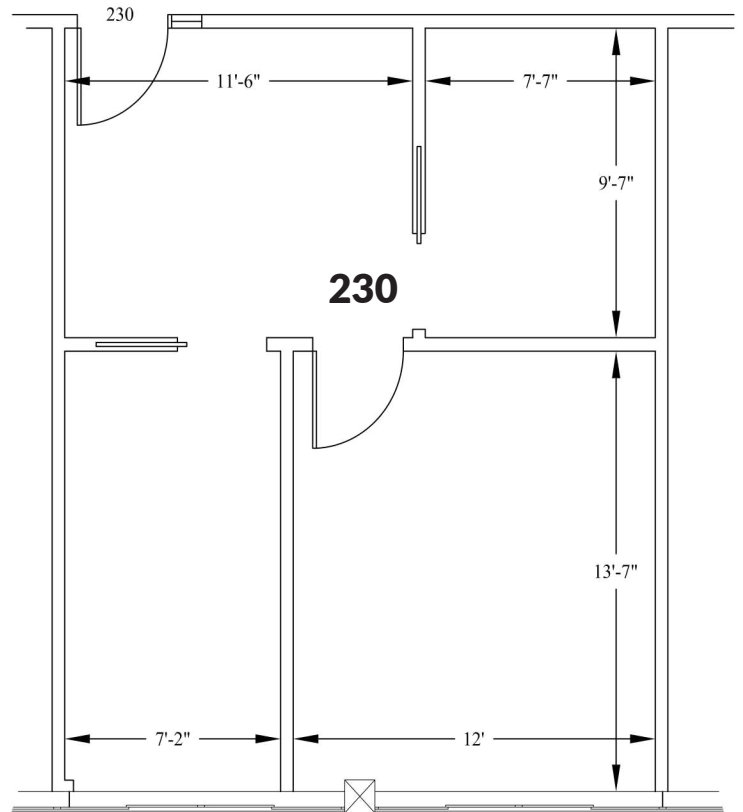

SUITE 250

Price:
\$1,209 / Month
Space Size:
± 907 SF
AVAILABLE NOW

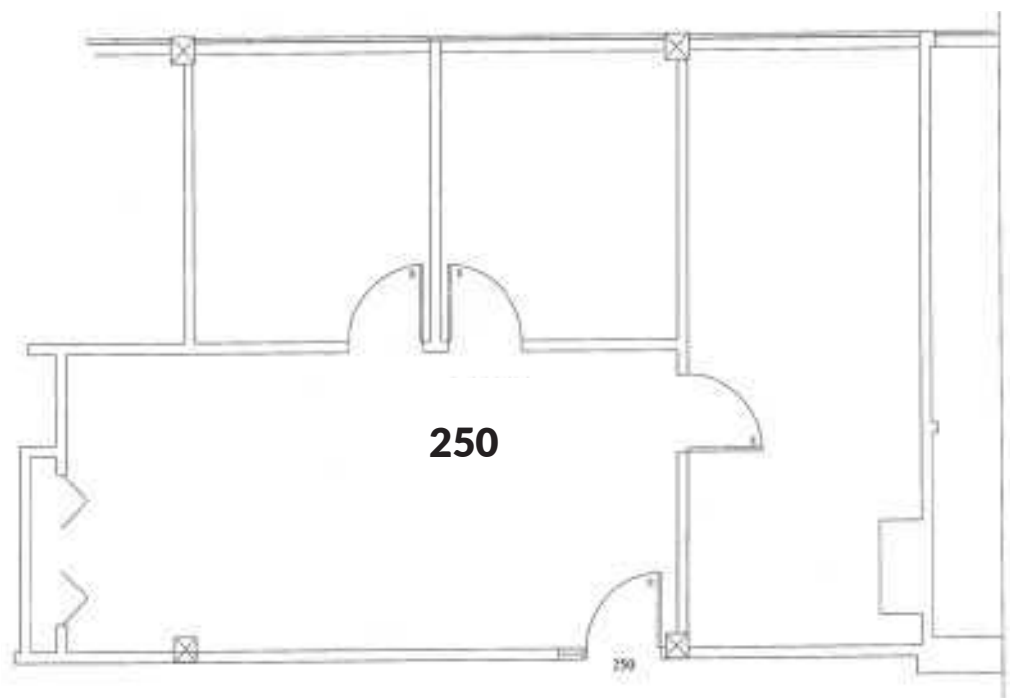

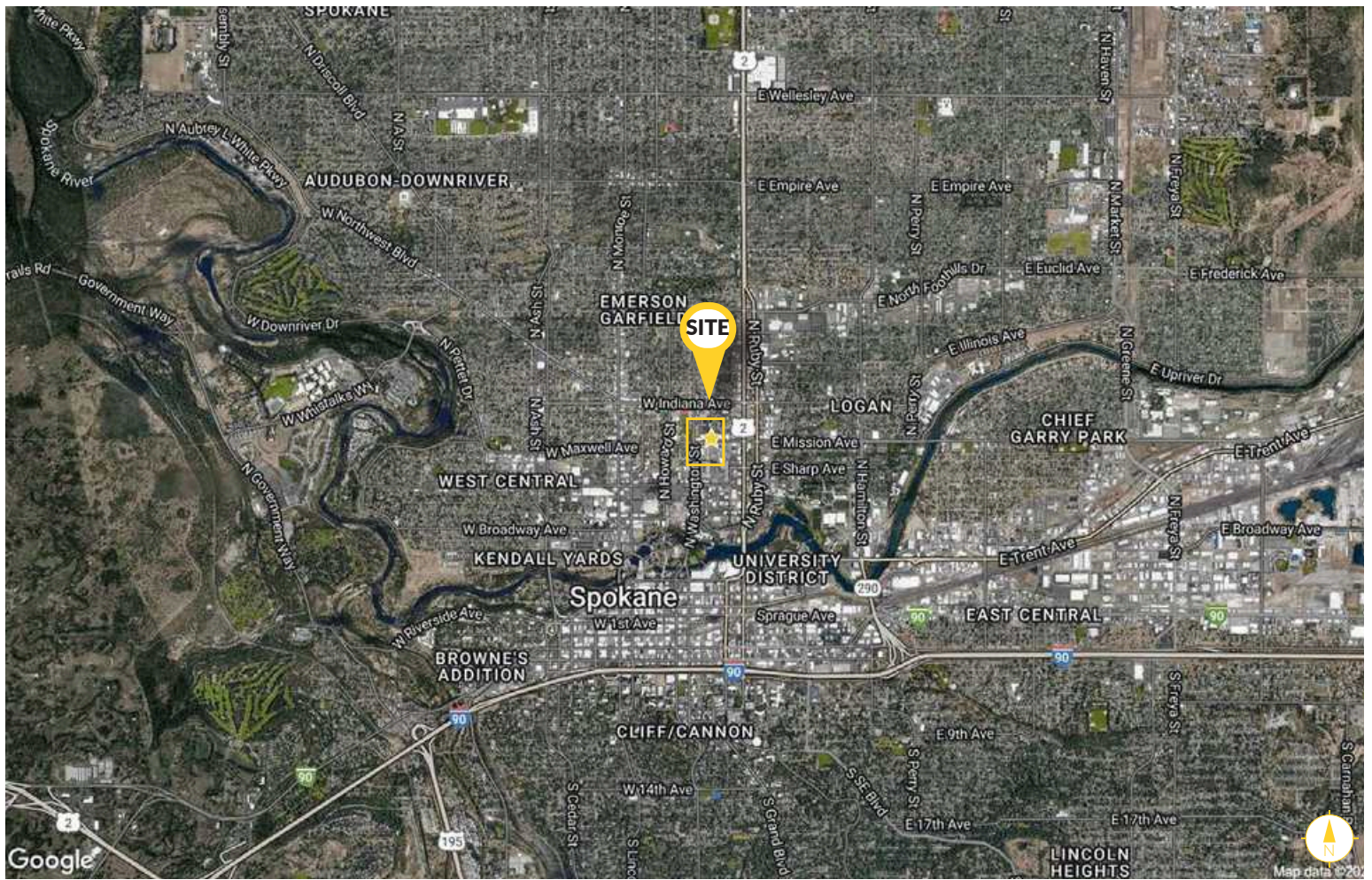

GARDEN COURT BUILDING

222 W Mission Avenue
Spokane, WA 99201

CHRISTIAN ALFARO, BROKER

509.755.7505 christian.alfaro@kiemlehaagood.com

TONY KING, PROPERTY MANAGER

509.755.7517 tony.king@kiemlehaagood.com

601 WEST MAIN AVENUE, SUITE 400
SPOKANE, WA 99201



OFFICE LOCATIONS

SPOKANE | COEUR D'ALENE | TRI-CITIES | PALOUSE | MISSOULA

No warranty or representation, expressed or implied, is made by Kiemle Haagood, its agents or its employees as to the accuracy of the information contained herein. All information furnished is from sources deemed reliable and submitted subject to errors, omissions, change of terms and conditions, prior sale, lease or financing, or withdrawal without notice. No one should rely solely on the above information, but instead should conduct their own investigation to independently satisfy themselves.

Kiemle Haagood respects the intellectual property of others:

If you believe the copyright in your work has been violated through this Website, please contact our office for notice of claims of copyright infringement. For your complaint to be valid under the Digital Millennium Copyright Act of 1998 (DMCA), you must provide the following information when providing notice of the claimed copyright infringement: Identify the material on the Website that you believe infringes your work, with enough detail so that we may locate it on the Website; provide your address, telephone number and email address; provide a statement that you have a good faith belief that the disputed use is not authorized by the copyright owner, its agent, or the law; provide a statement that the information in the notification is accurate, and under penalty of perjury, that the complaining party is authorized to act on behalf of the owner of an exclusive right that is allegedly infringed; and provide your physical or electronic signature. Upon receiving your complaint, Kiemle Haagood will, upon review, remove content that you believe infringes your copyright if the complaint is found to be valid.