

71,613 SF COLD STORAGE BUILDING

18404 72ND AVE S, KENT, WA

FOR LEASE



NEWMARK

THAD MALLORY, SIOR
Executive Vice Chairman
425-362-1410
thad.mallory@nmrk.com

TAYLOR HOFF, SIOR
Vice Chairman
425-362-1388
taylor.hoff@nmrk.com

PROPERTY HIGHLIGHTS

18404
72ND AVE S, KENT, WA

	Total Building: 71,613 SF
Building:	Office: 10,000 SF With Mezzanine Office In Two Nodes
Yard:	17,575 SF Fenced Yard For Trailer & Car Parking
Power:	1,600 amps - 277/480v Tenant to Verify
Clear Height:	24'
Loading:	13 Dock High Doors 1 Grade Level Door
Notes:	<ul style="list-style-type: none">◇ Available 5/1/2026◇ Variable Cold Storage◇ -20° Freeze Warehouse With Ante Rooms And Adjacent Dry Warehouse◇ M-1 Zoning◇ Chilled Dock◇ Slab Freezer Floor In Place, Built-In Glycol Floors



SITE PLAN

18404
72ND AVE S, KENT, WA

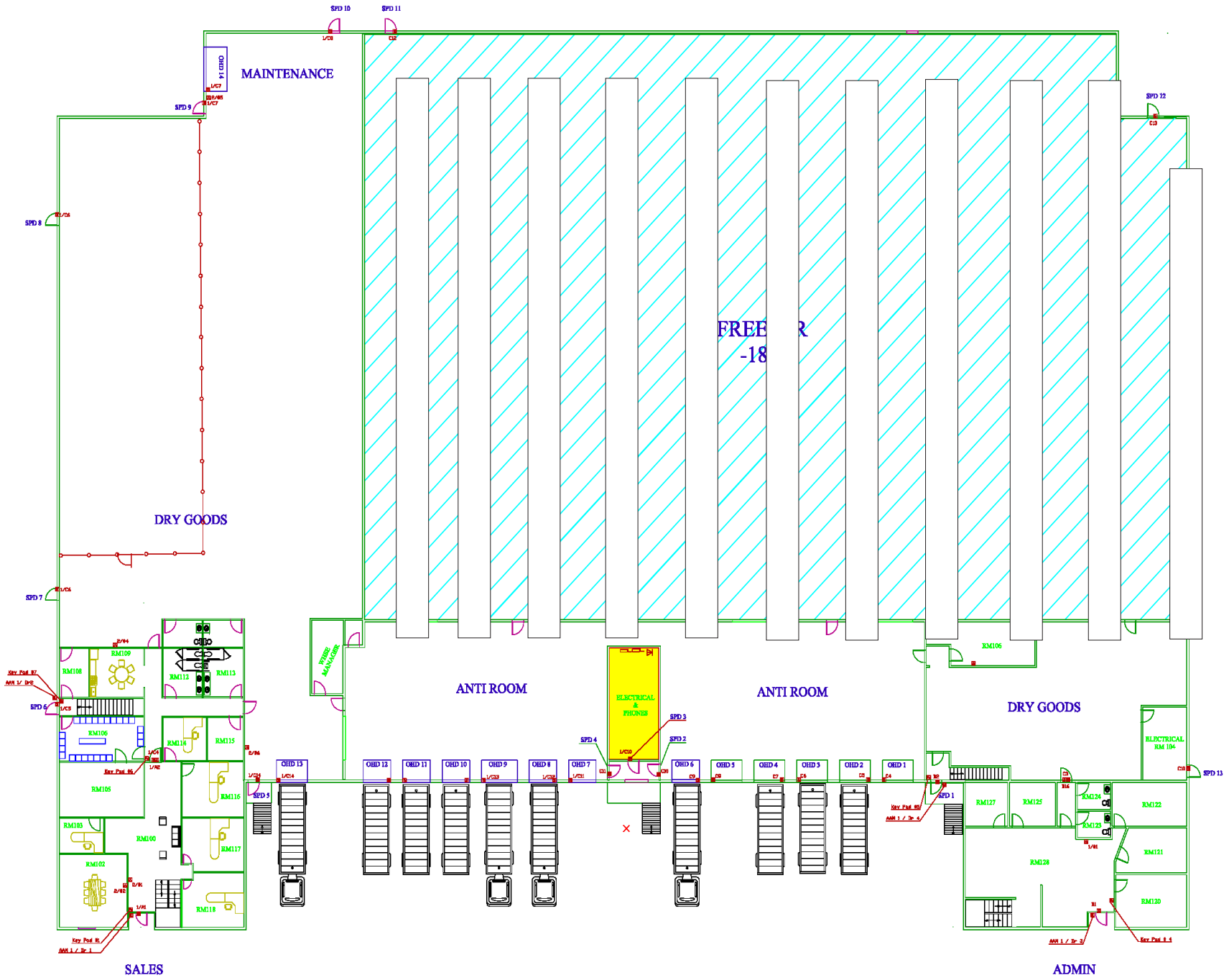

AERIAL MAP

18404
72ND AVE S, KENT, WA

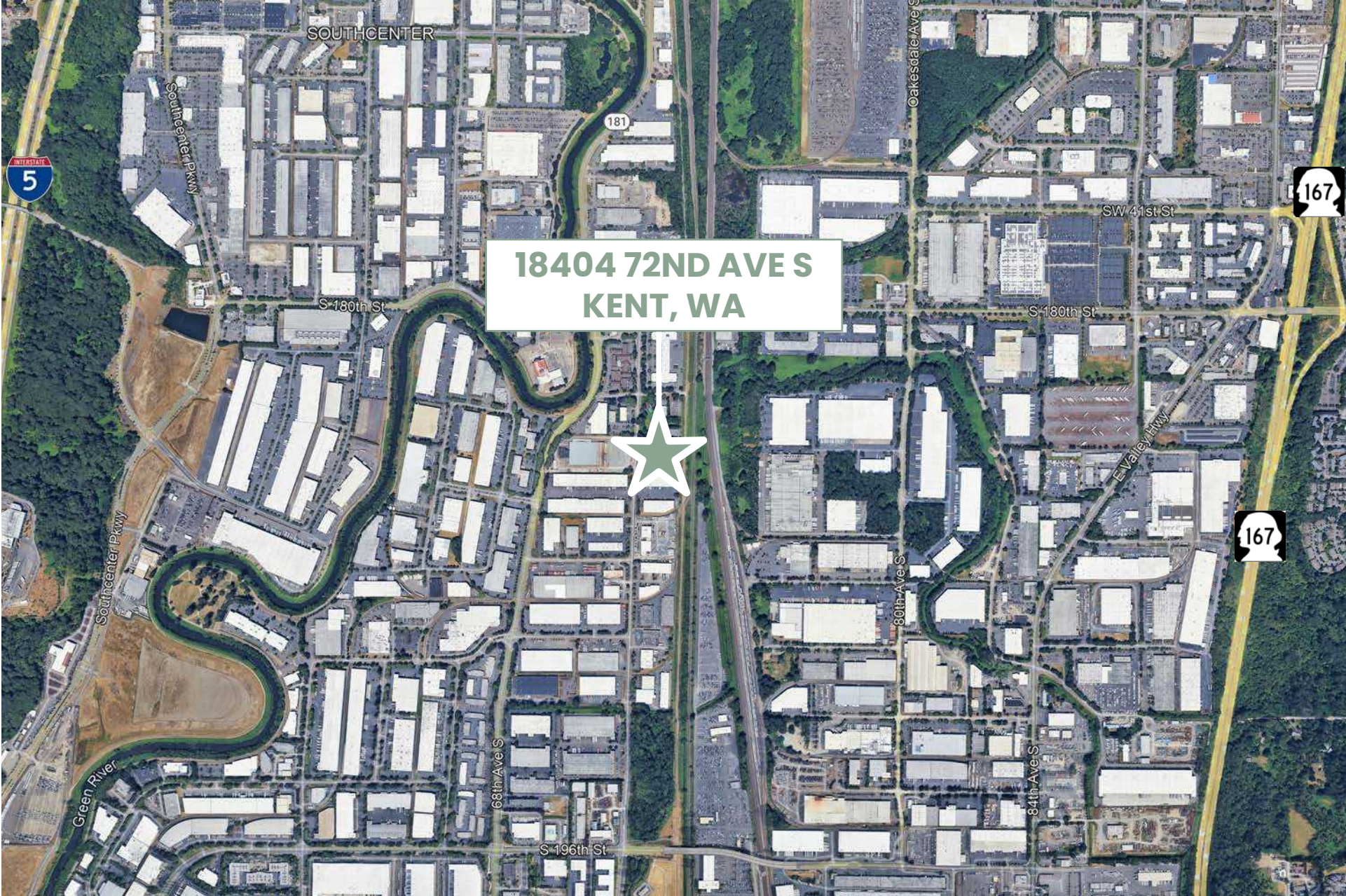

71,613 SF COLD STORAGE BUILDING

18404 72ND AVE S, KENT, WA

FOR LEASE



NEWMARK

The distributor of this communication is performing acts for which a real estate license is required. The information contained herein has been obtained from sources deemed reliable but has not been verified and no guarantee, warranty or representation, either express or implied, is made with respect to such information. Terms of sale or lease and availability are subject to change or withdrawal without notice.