

FOR LEASE
4500 Pacific Hwy E
Fife, WA 98424



FIFE PACIFIC PLAZA

Jacob Fors | Andy Jessberger

First Western Properties—Tacoma Inc. | 253.472.0404
6402 Tacoma Mall Blvd, Tacoma, WA 98409 | fwp-inc.com

FIFE PACIFIC PLAZA offers outstanding visibility and direct access from one of the region's busiest commercial corridors, just minutes from I-5. This high-traffic location is strategically positioned between Tacoma and Federal Way, making it ideal for businesses seeking regional exposure and convenient logistics.

AVAILABLE

- » SUITE C: 1,181 SF \$22.00 PSF + NNN
- » SUITE M: 1,170 SF \$22.00 PSF + NNN

- Well established shopping center with a great mix of national & local tenants.
- Ample parking available.
- Easy access from I-5 and WA-509.
- Excellent exposure.
- NNN Estimated at \$9.00



Population



Average HH Income



Daytime Population

Regis - 2026

	Population	Average HH Income	Daytime Population
Mile 1	3,388	\$110,283	7,371
Mile 3	49,572	\$123,588	37,289
Mile 5	235,934	\$121,764	163,268

TENANTS



H&R BLOCK



NEARBY TENANTS

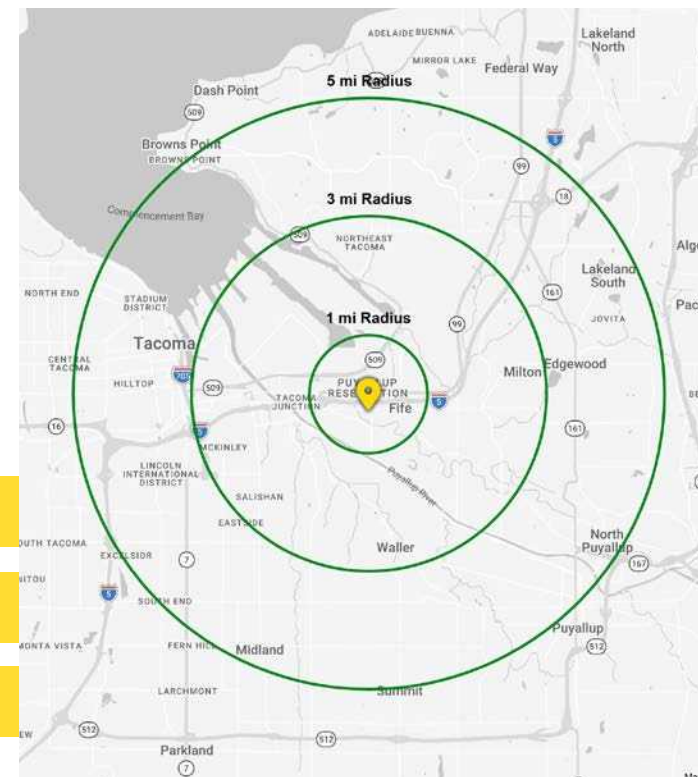

LOCATION DETAILS

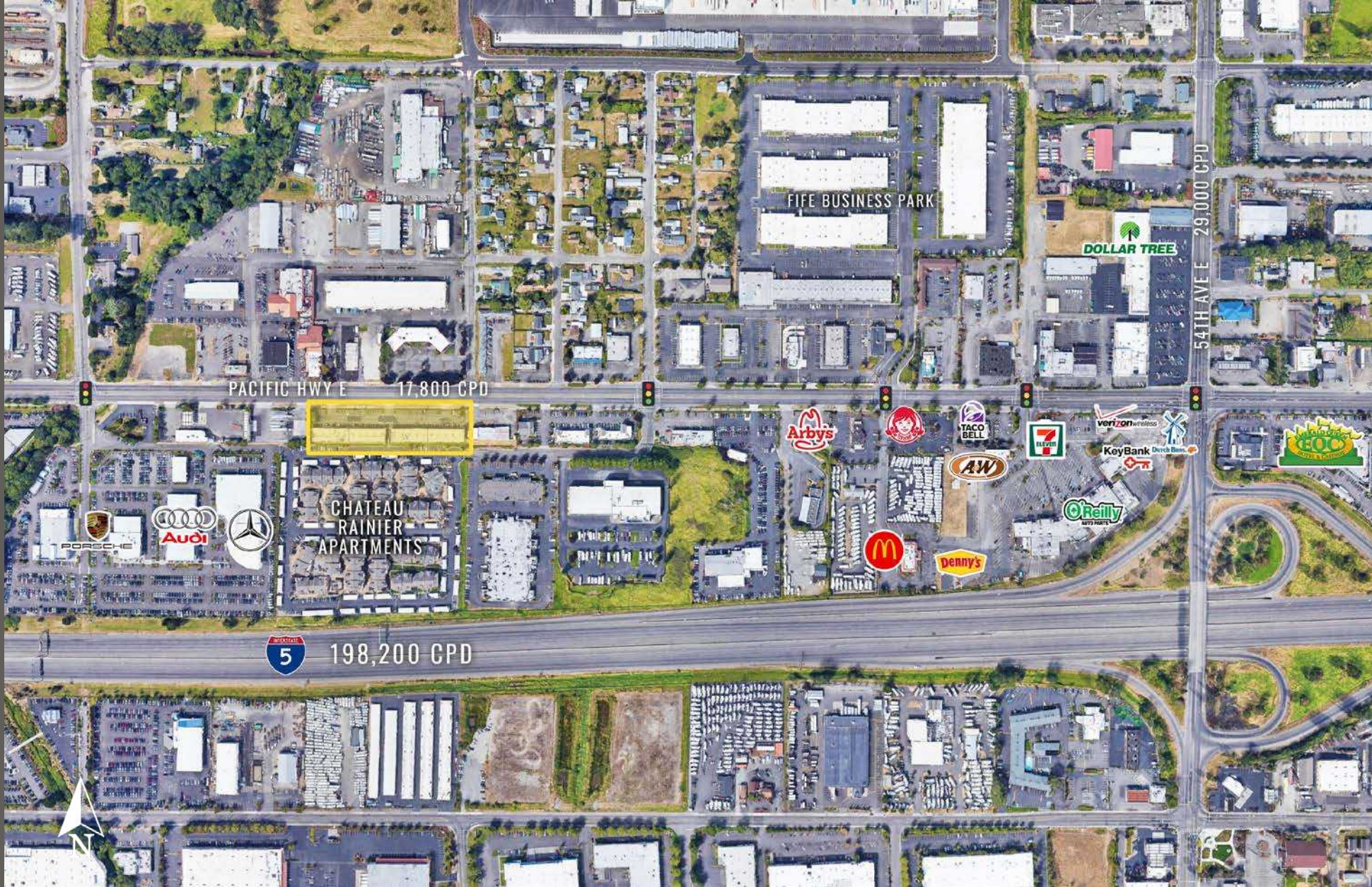

Blocks away from
I-5 & WA 509



10 minute drive to
Downtown Tacoma



17,800 CPD
Pacific Hwy E



29,000 CPD
54th Ave E

MARKET AERIAL

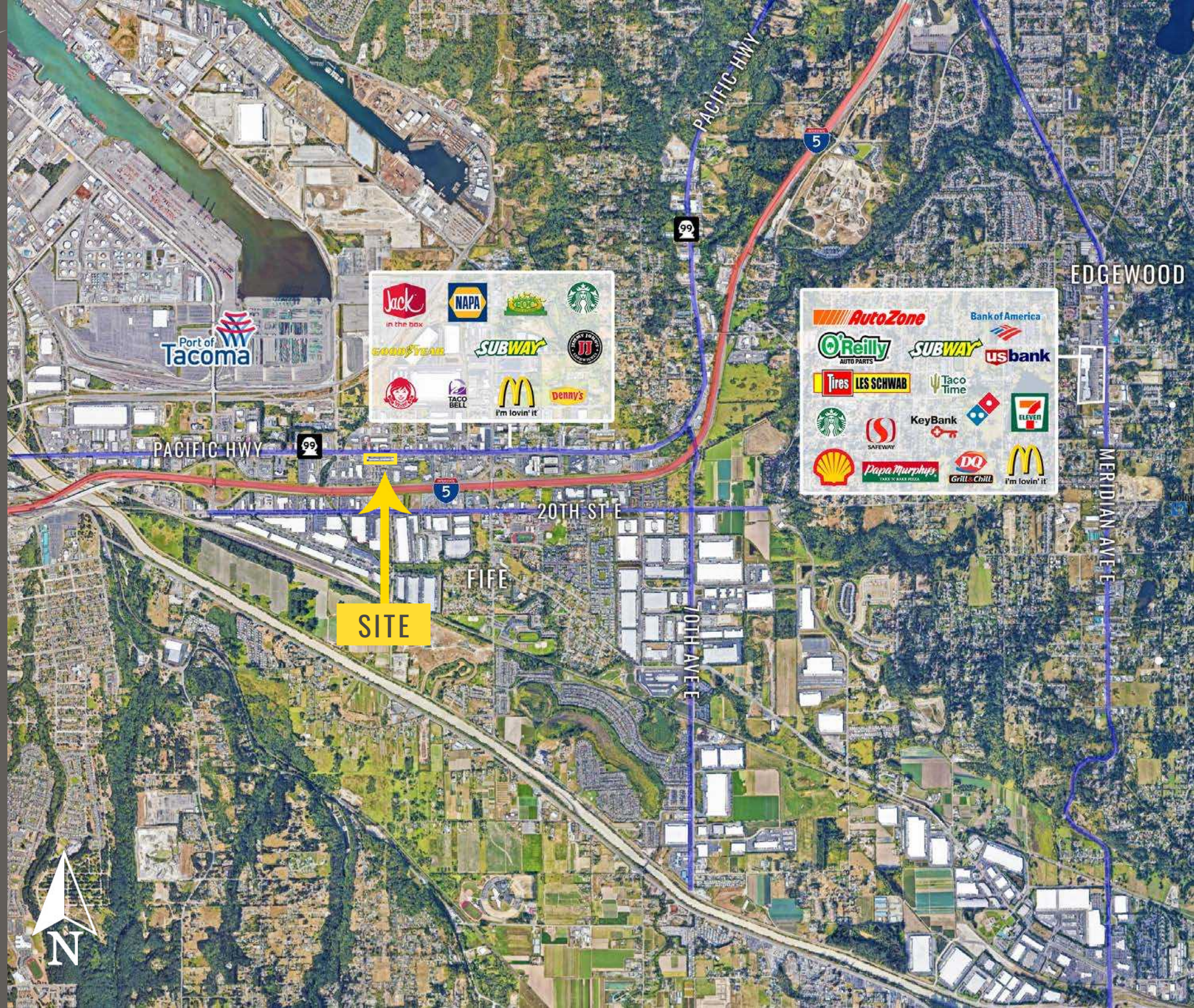

Port of
Tacoma

Jack
in the box

NAPA

Starbucks

Goodyear

SUBWAY

Dunkin' Donuts

TACO BELL

McDonald's
I'm lovin' it

Denny's

AutoZone

Bank of America

O'Reilly
AUTO PARTS

SUBWAY

usbank

Tires

LES SCHWAB

Taco Time

Starbucks

SAFeway

KeyBank

Domino's

7-ELEVEN

Shell

Papa Murphy's
TAKE 'N BAKE PIZZA

DQ
Grill & Chill

McDonald's
I'm lovin' it

EDGEWOOD

MERIDIAN AVE E

PACIFIC HWY

5

99

PACIFIC HWY

99

5

20TH ST E

FIFE

70TH AVE E

SITE

SITE PLAN

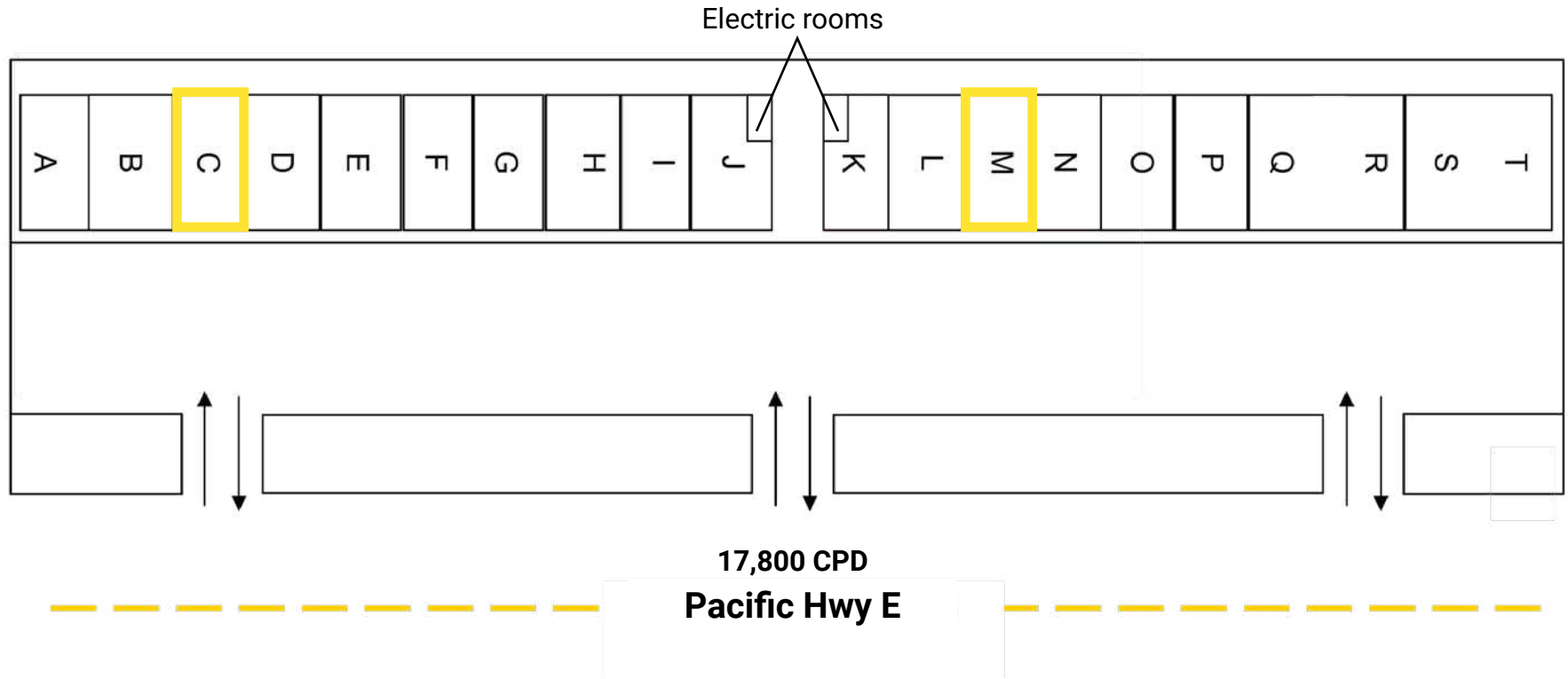

SUITE	SF	TENANT
A	1,324	Nirvana Asian Massage
B	1,016	The Barber Lounge
C	1,181	AVAILABLE
D	1,170	Prov Inc.
E	1,183	Total Wireless
F	1,170	Super Hairstyles
G	1,170	Thrift Staffing
H	1,170	H&R Block
I	1,170	Ichiban Teriyaki

SUITE	SF	TENANT
J	1,098	Sunny Donuts
K	1,084	Taqueria Los 3 Hermanos
L	1,170	Nail Arts
M	1,170	AVAILABLE
N	1,176	Hippie Hut
O	1,183	Metro PCS
P	1,480	Wingstop
Q/R	2,030	Top Pho
S/T	2,340	Thai Restaurant of Fife

TACOMA | KIRKLAND | PORTLAND | SEATTLE

RELATIONSHIP FOCUSED.
RESULTS DRIVEN.



JACOB FORS

 253.472.0472

 jfors@firstwesternproperties.com

ANDY JESSBERGER

 253.471.5507

 andy@firstwesternproperties.com



First Western Properties—Tacoma Inc. | 253.472.0404
6402 Tacoma Mall Blvd, Tacoma, WA 98409 | fwp-inc.com

© First Western Properties, Inc. DISCLAIMER: The above information has been secured from sources believed to be reliable, however, no representations are made to its accuracy. Prospective tenants or buyers should consult their professional advisors and conduct their own independent investigation. Properties are subject to change in price and/or availability without notice.