



# Woodinville Corporate Park

15300-15500 & 16240-16750 Woodinville-Redmond Rd

Space Available  
For Lease Within a  
928,000 SF Class-A  
Industrial Park



SCAN TO VIEW WEBSITE

[woodinvillecorporatepark.com](http://woodinvillecorporatepark.com)





12 State-of-the-Art,  
Freestanding, Dock-High,  
Class-A Industrial Buildings in  
Woodinville's Premier Location

**928,000 SF**

Total Size of Park



Loading door  
ratio: 1 door per  
3,067 SF



24' clear height



Excellent  
truck courts



Parking ratio:  
1.35 stalls per  
1,000 SF



# Highlights

## Best-in-class industrial on the Eastside

- Easy access to SR-522 & I-405
- Situated close to downtown Woodinville amenities
- Market leading functionality: true 24' clear, dock + grade loading, with excellent truck courts

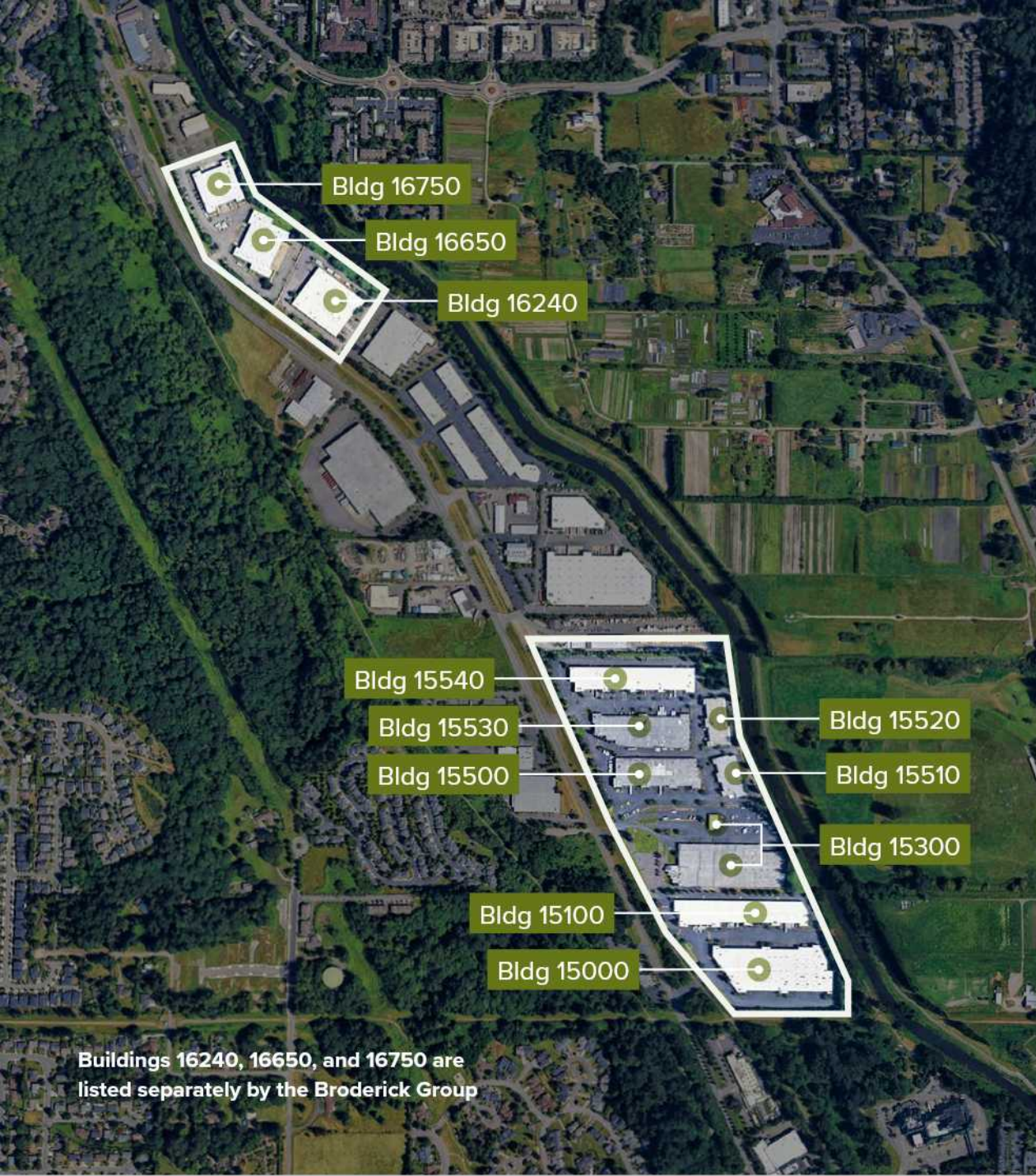

Buildings 16240, 16650, and 16750 are listed separately by the Broderick Group



# Building 15000 Suite 900

## First Floor

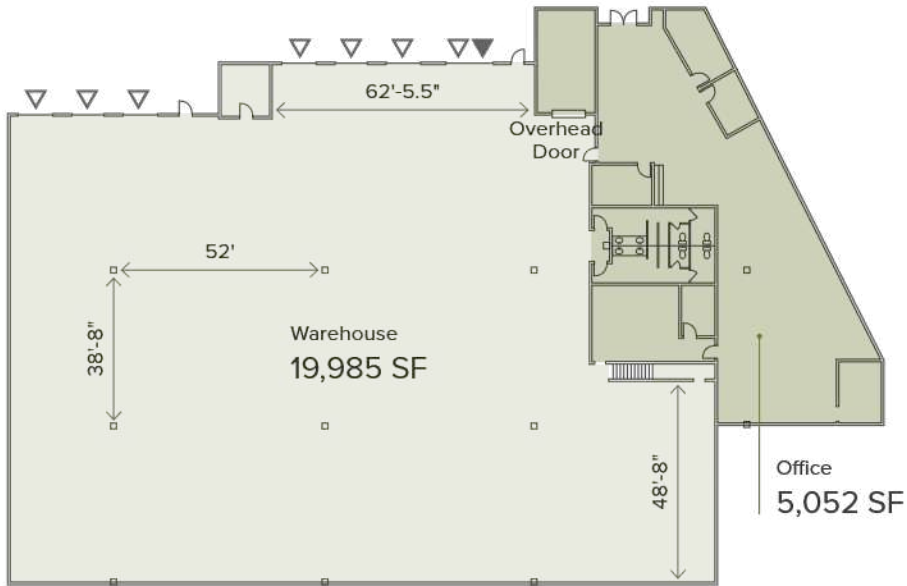

## Mezzanine

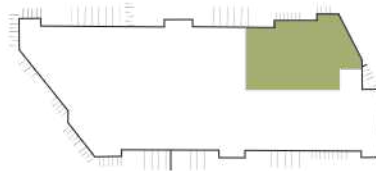
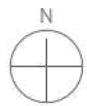
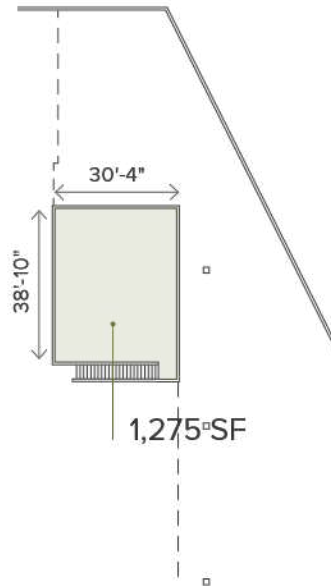

Available Now  
Call for Rates

### Planned improvements

- New carpet
- New paint
- New LED lighting
- New ceiling tiles
- 24' clear height
- 7 dock high / 1 grade level
- 200 amps, 480V, 3-phase power

First-Floor Office	5,052 SF
Second-Floor Mezz.	1,275 SF
Warehouse	19,985 SF
<b>Total Space</b>	<b>26,312 SF</b>



# Building 15100 Suite 600

## First Floor

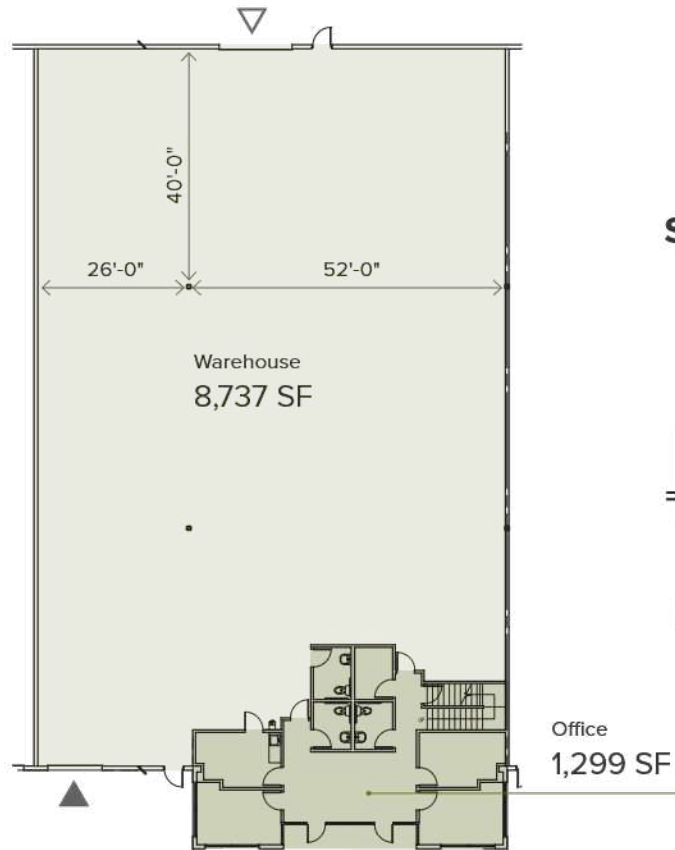

## Second Floor Office

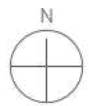
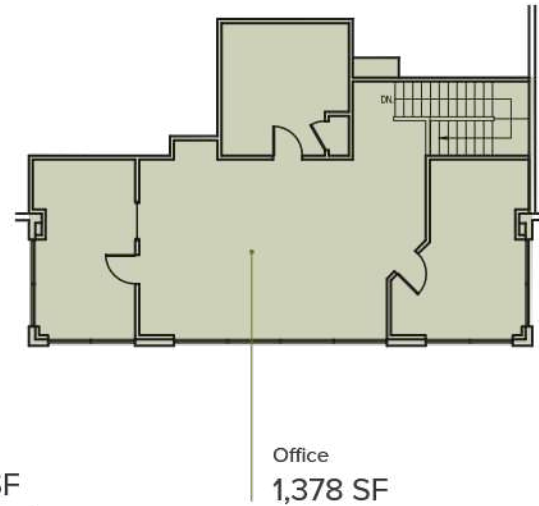

- Office
- Warehouse
- Dock-High Loading
- Grade-Level Loading



Available Now  
Call for Rates

### Features

- New carpet
- New paint
- New LED lighting
- 24' clear height
- 1 dock high / 1 grade level

First-Floor Office	1,299 SF
Second-Floor Office	1,378 SF
Warehouse	8,737 SF
<b>Total Space</b>	<b>11,414 SF</b>



# Building 15500 Suite 100

## First Floor

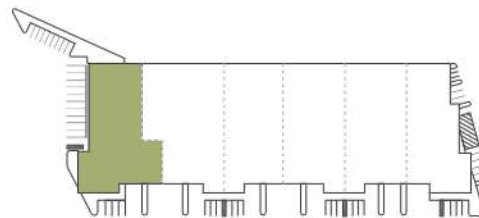
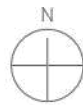
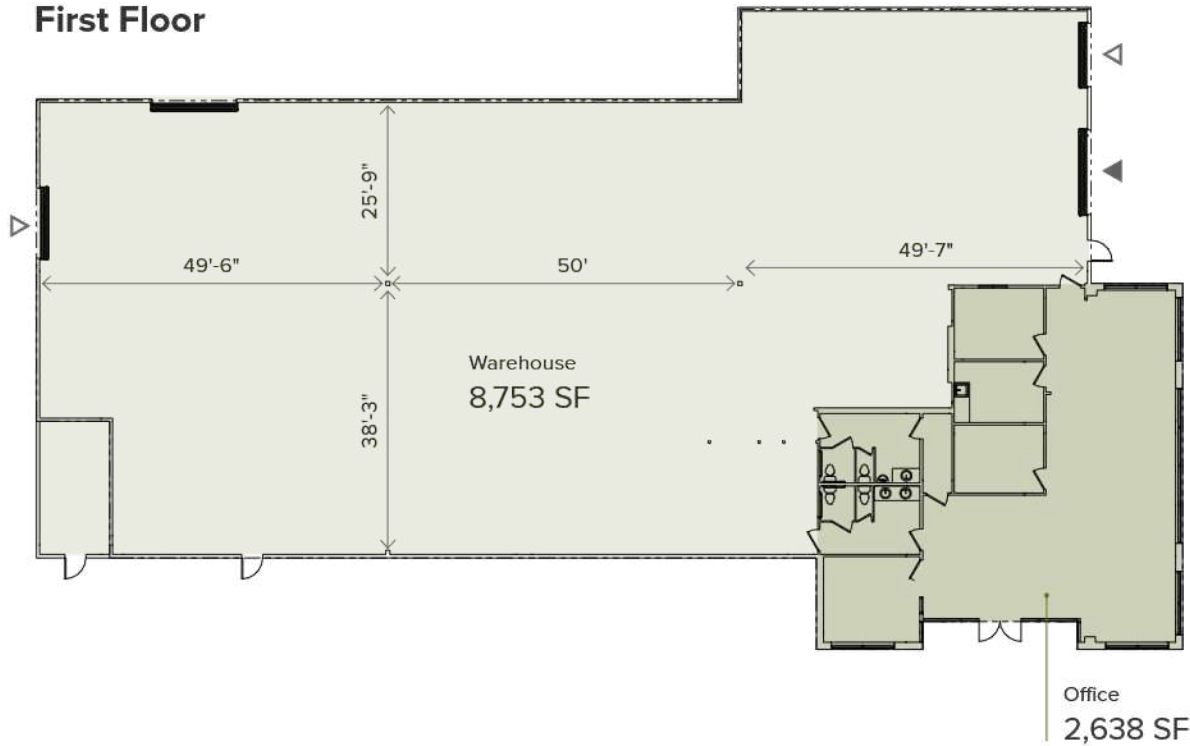

Available Now  
Call for Rates

### Planned Improvements

- New carpet
- New paint
- New LED lighting
- 24' clear height
- 2 dock high / 1 grade level
- 200 amps, 480V 3-phase meter/panel (expandable to 400 amps)

Office	2,638 SF
Warehouse	8,753 SF
<b>Total Space</b>	<b>11,391 SF</b>



# Building 15500

## Suites 200/300/400

Available Now  
Call for Rates

### Planned Improvements

- New LED lighting
- New warehouse finishes
- New office finishes
- New carpet
- Divisible space—  
12,934–41,426 SF available
- 24' clear height
- 10 dock high / 3 grade level
- 800 amps, 480V  
(expandable to 1,000  
amps)

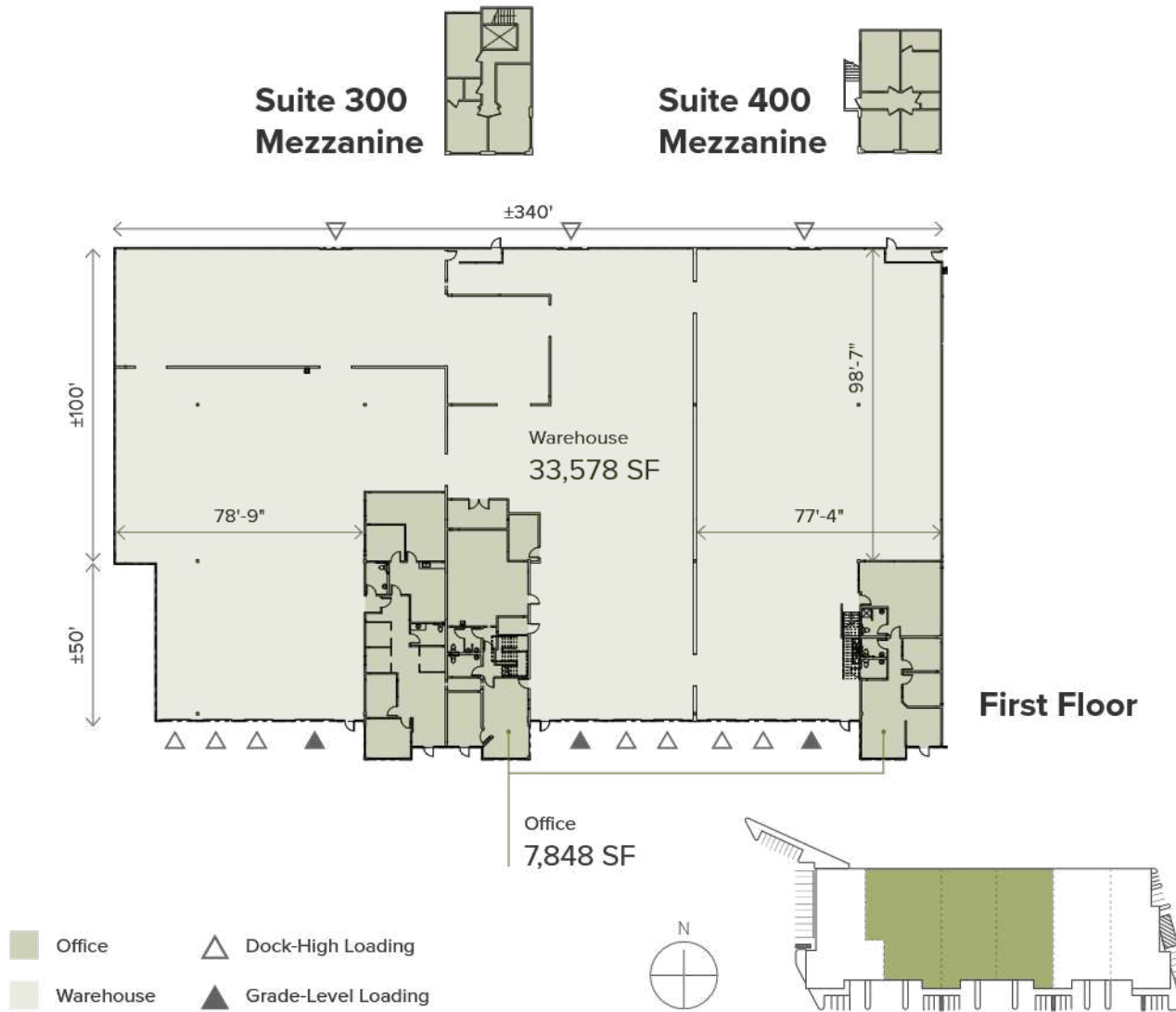

Office	7,848 SF
Warehouse	33,578 SF
<b>Total Space</b>	<b>41,426 SF</b>



# Building 15520 Suite 100

## First Floor

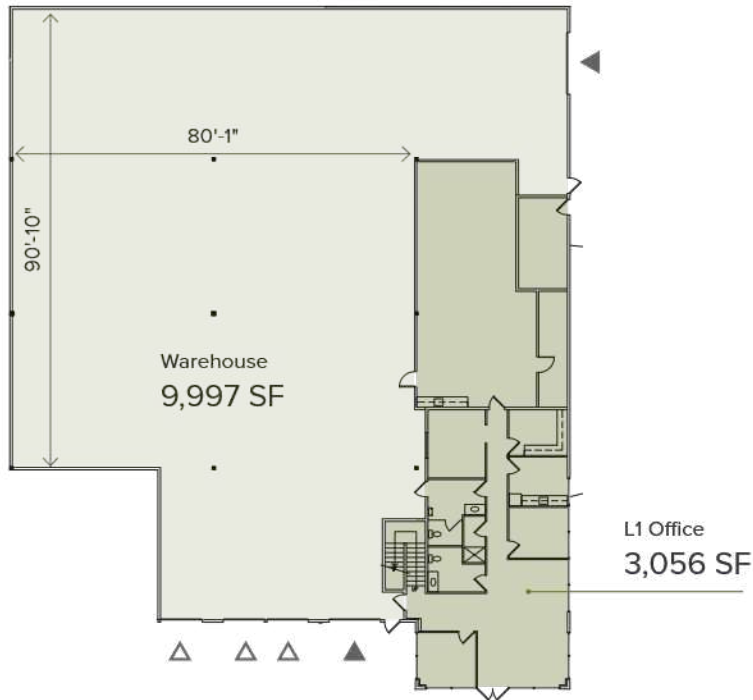

## Second Floor Office

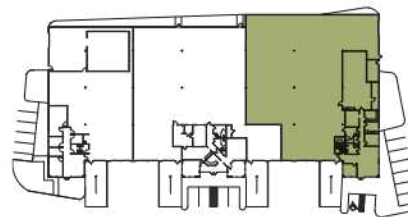
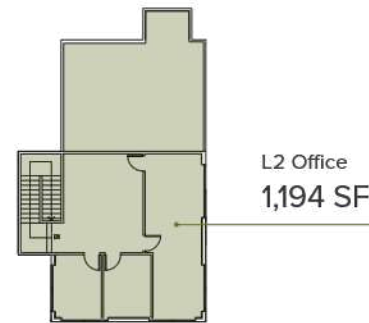

- Office
- Warehouse
- Dock-High Loading
- Grade-Level Loading



Available 7/1/26  
Call for Rates

### Features

- New roof
- New warehouse LEDs and paint
- New office finishes
- 24' clear height
- 3 dock high / 2 grade level
- 500 amps, 480V, 3-phase power

First Floor Office	3,056 SF
Second Floor Office	1,194 SF
Warehouse	9,997 SF
<b>Total Space</b>	<b>14,247 SF</b>



# Building 15530 Suite 300

## First Floor

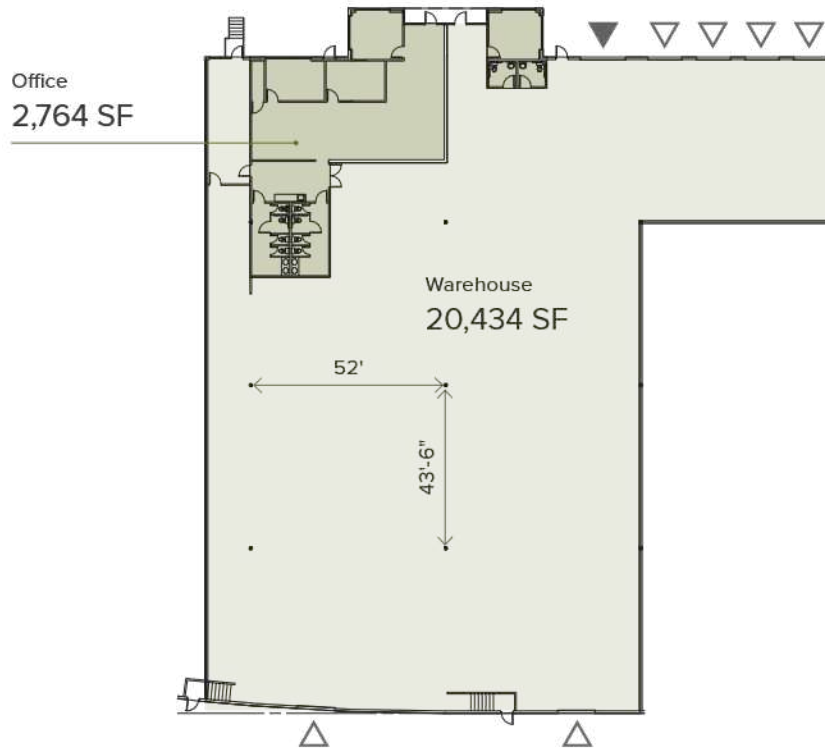

Available 10/1/26  
Call for Rates

### Planned improvements

- New warehouse LEDs and paint
- New office finishes
- 24' clear height
- 6 dock high / 1 grade level
- 500 amps, 480V, 3-phase power

Office	2,764 SF
Warehouse	20,434 SF
<b>Total Space</b>	<b>23,198 SF</b>



# Building 15300 + Yard

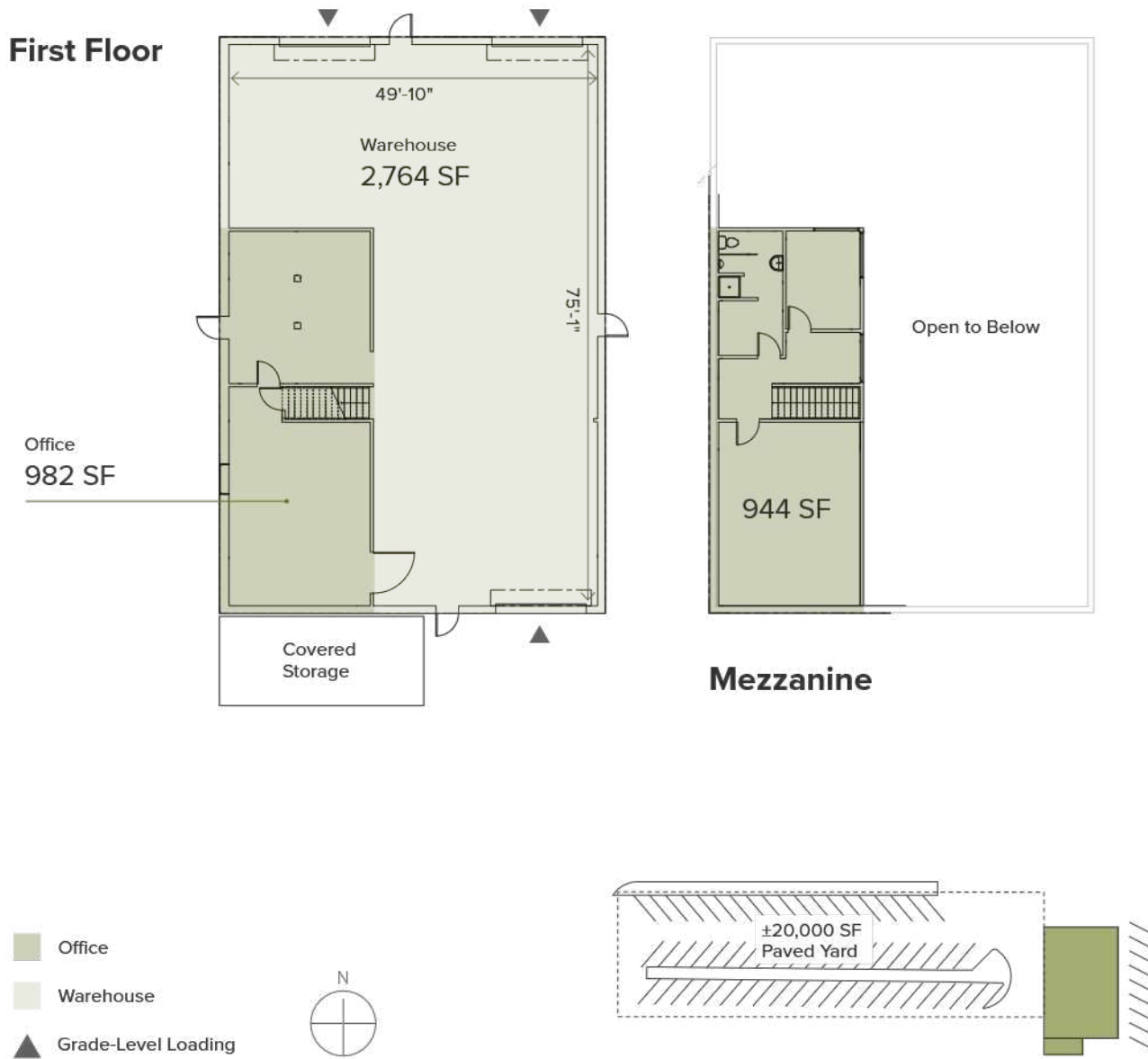

Available  
30 Days Notice  
Call for Rates

## Features

- Stand-alone building with 20,000 SF of paved yard (can be fenced)
- 3 grade-level doors
- Includes outside covered storage area

First Floor Office	982 SF
Unfinished Mezz.	944 SF
Warehouse	2,764 SF
<b>Total Space</b>	<b>4,690 SF</b>



# Upcoming Park Improvements



New Landscaping



Refreshed Building Exteriors



New Park Signage



Local Institutional Ownership



Tenant Experience Upgrades



Mechanical & Roof Upgrades





# Nearby Amenities

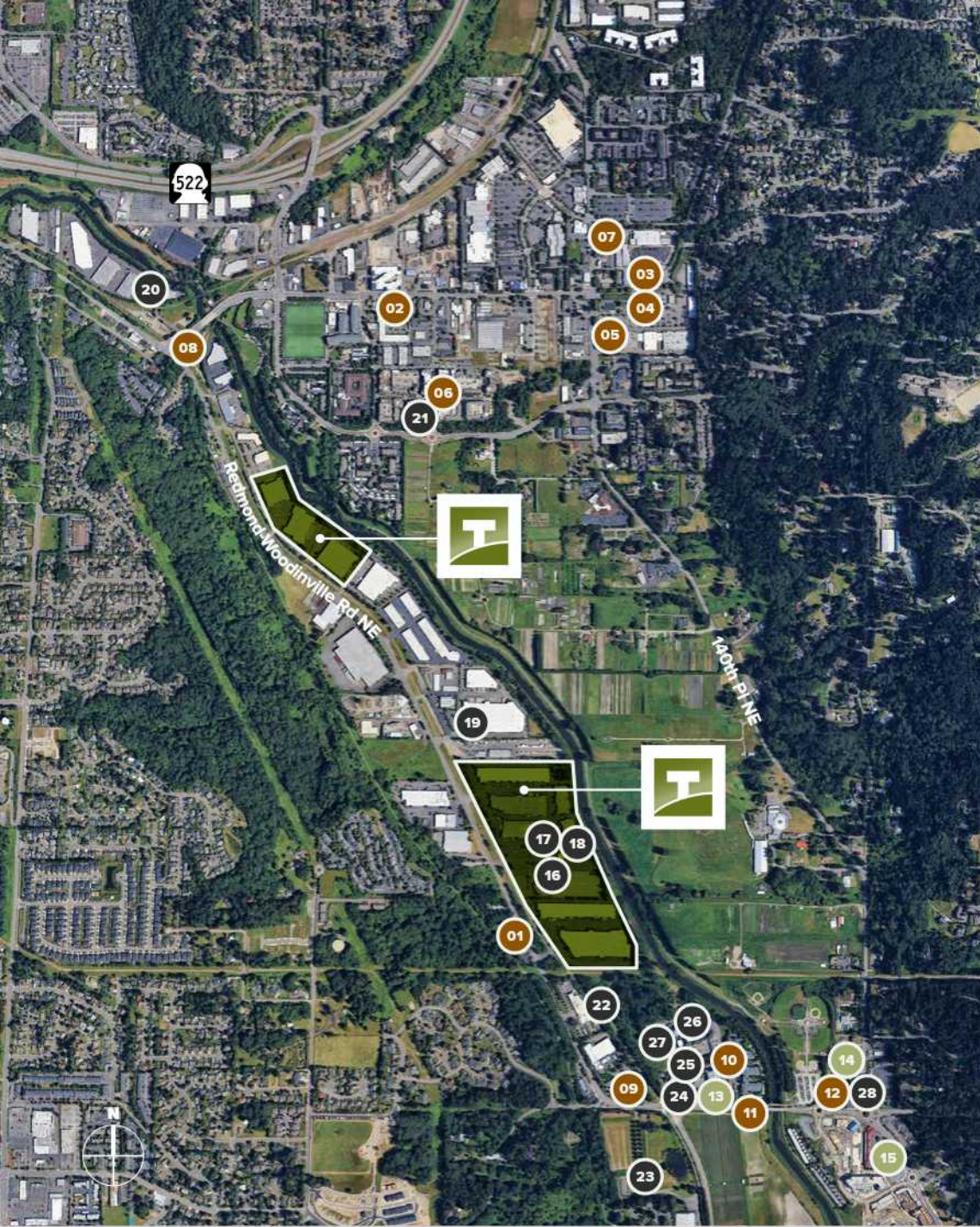

## EAT & DRINK

- 01 Von's 1000Spirits
- 02 The Pizza Coop & Ale House
- 03 Woodinville Café
- 04 Topsy Cow
- 05 Pasta Nova Italiano
- 06 Rusty Pelican Café
- 07 Dough Zone
- 08 Woodinville Cut Shop
- 09 Hollywood Tavern
- 10 Barking Frog
- 11 The Herbfarm
- 12 Vivi Pizzeria

## LODGING

- 13 Willows Lodge
- 14 Hollywood Manor at Tenhulzen Reserve
- 15 The Somm

## WINERIES & BREWERIES

- 16 Tenor Wines
- 17 Watts Brewing Company
- 18 Black Raven Brewing
- 19 Martedi Winery
- 20 Rocky Pond Estate Winery
- 21 Novelty Hill – Januik Winery
- 22 Chateau Ste. Michelle Winery
- 23 Mark Ryan Winery
- 24 Fidélitas
- 25 DeLille Cellars
- 26 Sparkman Cellars
- 27 Latta Wines
- 28 Patterson Cellars



# Drive Times

Located in the heart of Woodinville, with convenient drive-time access to top restaurants, retail, and key amenities

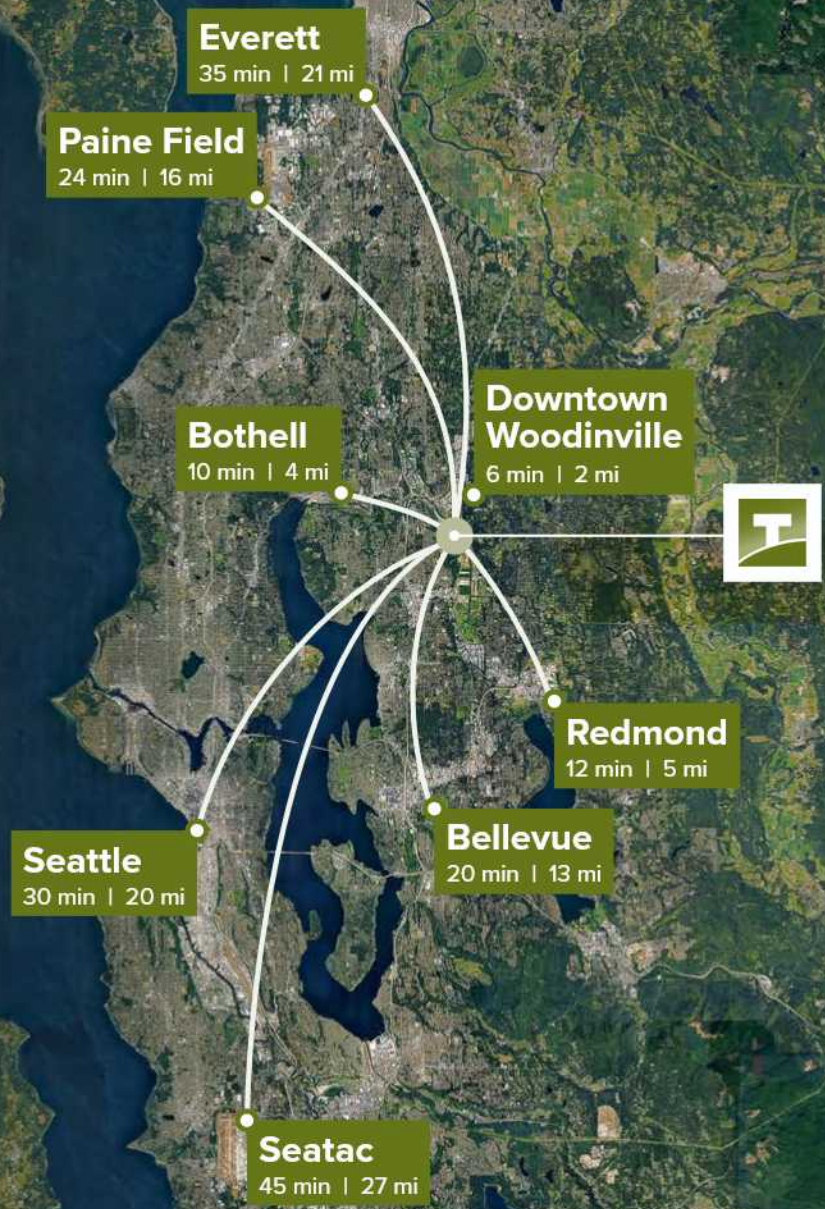

# Owner Profile



Industrial Real Estate  
Focused on **Location**,  
**Functionality**, and  
**Flexibility**.

307

Buildings

20.2M

Square Feet

44

Improved  
Land Parcels

676

Customers

Terreno Realty acquires,  
owns and operates  
**industrial real estate** in six  
major coastal U.S. markets.

These properties may be warehouse/distribution, flex  
(including light industrial and R&D), transshipment  
(truck terminals) or improved land parcels.



[LEARN MORE AT TERRENO.COM](https://www.terreno.com)





---

# Woodinville Corporate Park

15300 – 15500 Woodinville-Redmond Rd  
Woodinville, WA 98072

[woodinvillecorporatemark.com](http://woodinvillecorporatemark.com)    [kidder.com](http://kidder.com)

## Exclusively listed by

**Todd Gauthier**  
Executive Vice President  
425.450.1118  
[todd.gauthier@kidder.com](mailto:todd.gauthier@kidder.com)

**Jason Bloom**  
Executive Vice President  
425.450.1102  
[jason.bloom@kidder.com](mailto:jason.bloom@kidder.com)

**Carter Nicholson**  
Associate  
425.450.1145  
[carter.nicholson@kidder.com](mailto:carter.nicholson@kidder.com)

**Greg Fuchs**  
Associate  
425.450.1161  
[greg.fuchs@kidder.com](mailto:greg.fuchs@kidder.com)



SCAN TO  
LEARN MORE



This information supplied herein is from sources we deem reliable. It is provided without any representation, warranty, or guarantee, expressed or implied as to its accuracy. Prospective Buyer or Tenant should conduct an independent investigation and verification of all matters deemed to be material, including, but not limited to, statements of income and expenses. Consult your attorney, accountant, or other professional advisor.