



PROPERTY FOR SALE

THE WRAIGHT BUILDING

233 NORTH HOWARD STREET, SPOKANE, WA

CBRE

PROPERTY OVERVIEW

SPOKANE PROPERTY FOR SALE

Currently vacant, and ideally located in Spokane's downtown core, the Wraight building represents an ideal repositioning opportunity. With an asking price significantly below core replacement costs and zoned Downtown Core (DTC) for dense building and massing, the Wraight building holds potential for conversion to residential, hospitality, office or a variety of other uses.

HIGHLIGHTS

- Central downtown Spokane Location with easy access to the mall
- Recently replaced roof
- Across the street from Riverfront Park
- Multiple nearby parking options

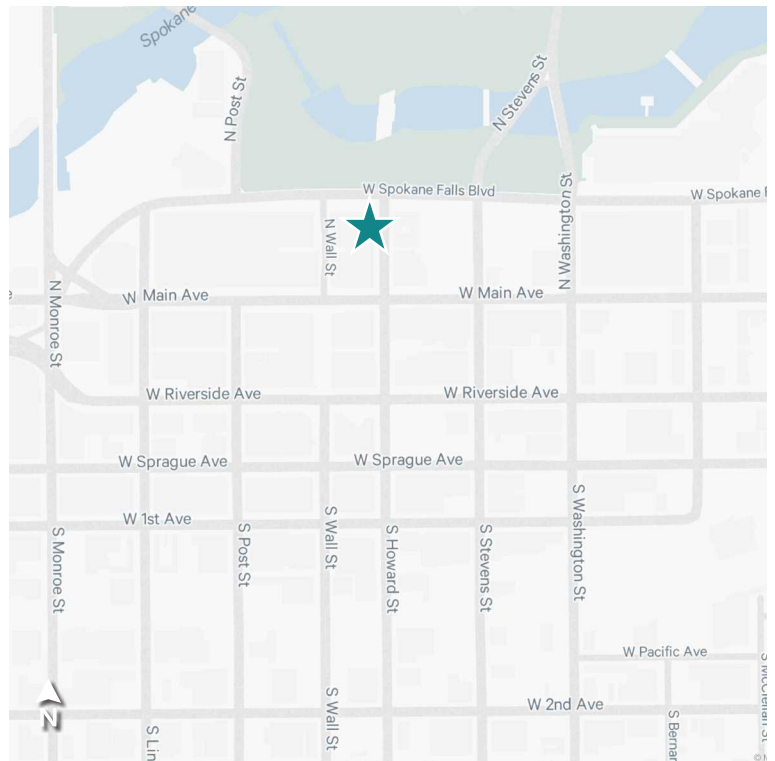

Asking Price: \$3,000,000
Building SF: 93,390, (10-stories)
Land SF: 0.24 AC
Address: 223 N Howard St
 Spokane, WA
Parcel #: 351841802
Zoning: Downtown Core (DTC)
Assessed Value: \$3,337,720

2024 DEMOGRAPHICS	1 MILE	3 MILES	5 MILES
BUSINESSES	3,509	6,507	9,739
EMPLOYEES	66,554	101,896	140,599
POPULATION	16,434	117,861	237,590
HOUSEHOLDS	8,198	50,120	98,548
AVERAGE HOUSEHOLD INCOME	\$59,298	\$85,056	\$90,646
DAYTIME POPULATION	80,800	171,694	280,494

Source: CBRE Fast Report/Esri 2024

FLOOR PLANS

Sub Basement

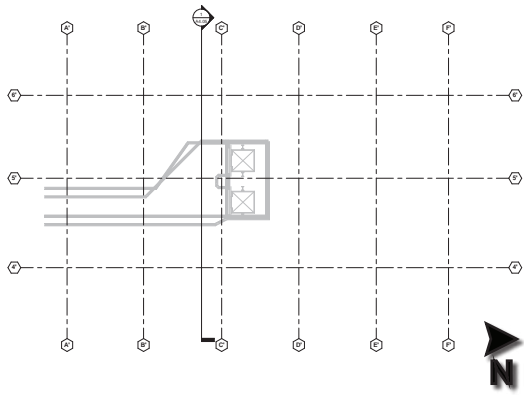

Basement

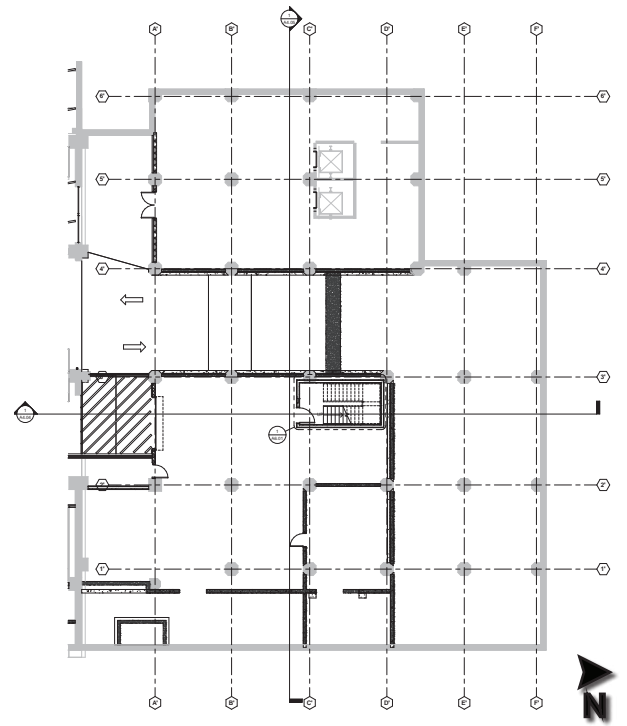

1st Floor

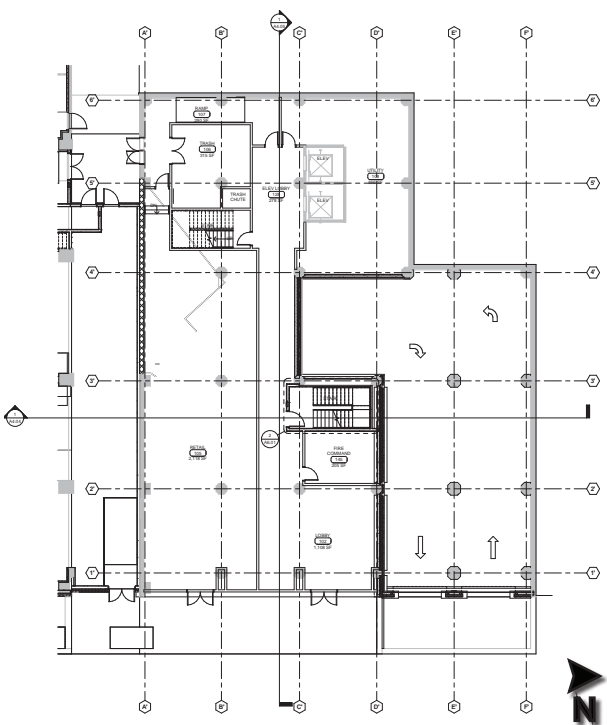

2nd Floor

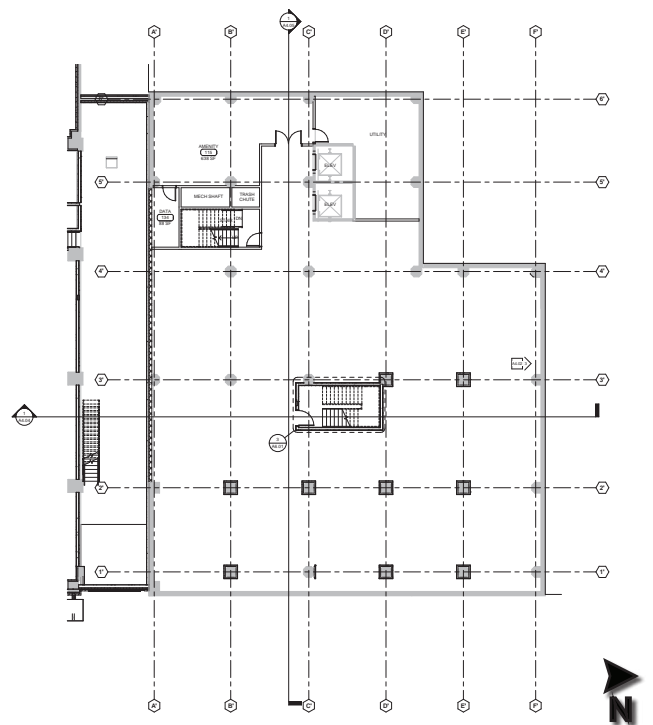

FLOOR PLANS

3rd Floor

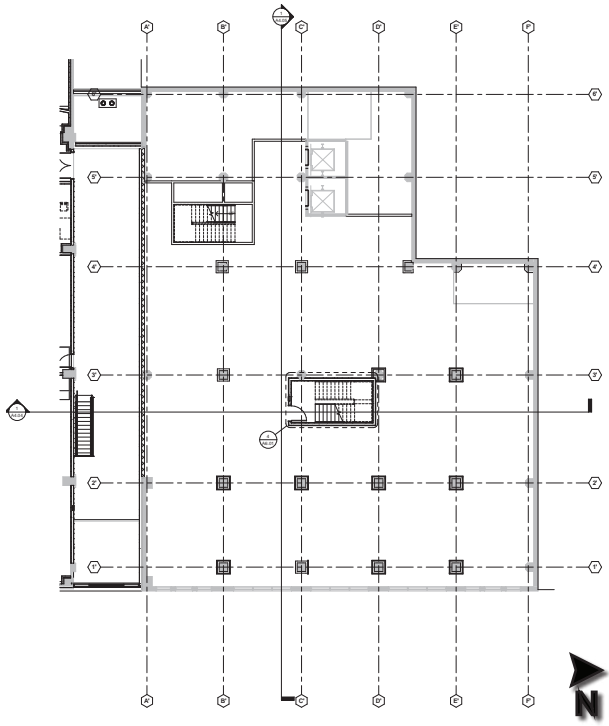

4th Floor

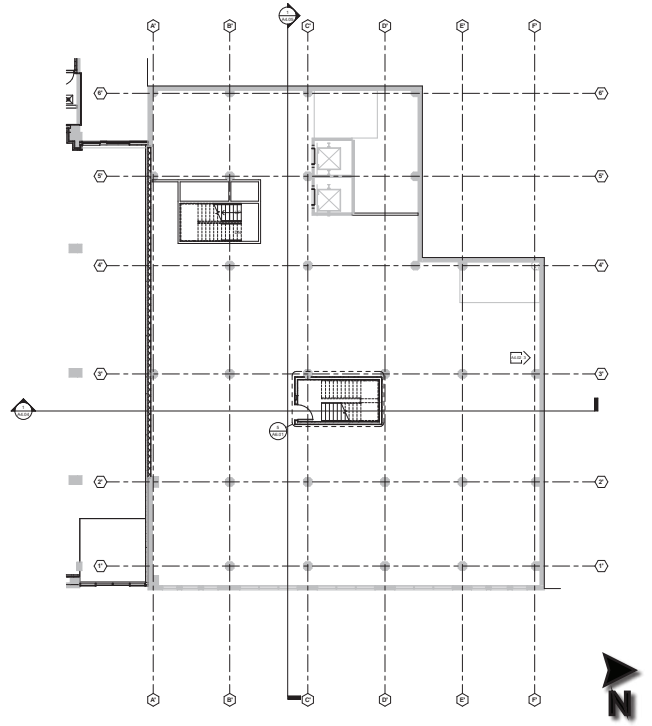

5th Floor

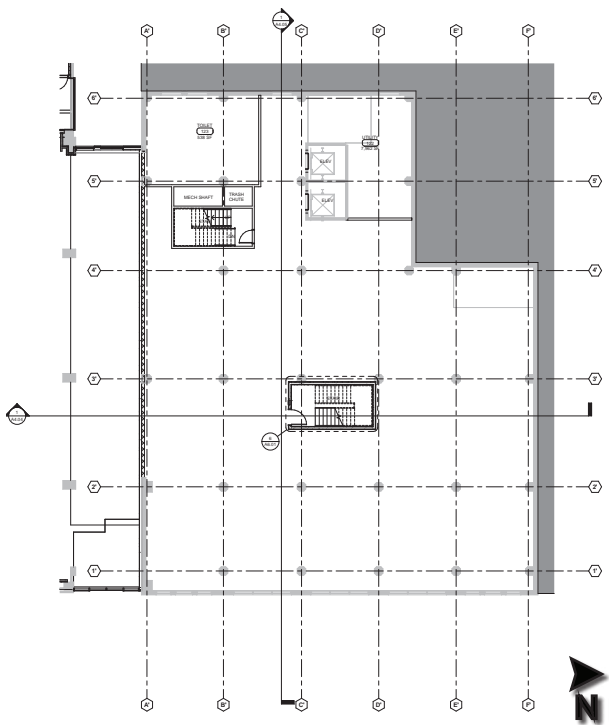

6th Floor

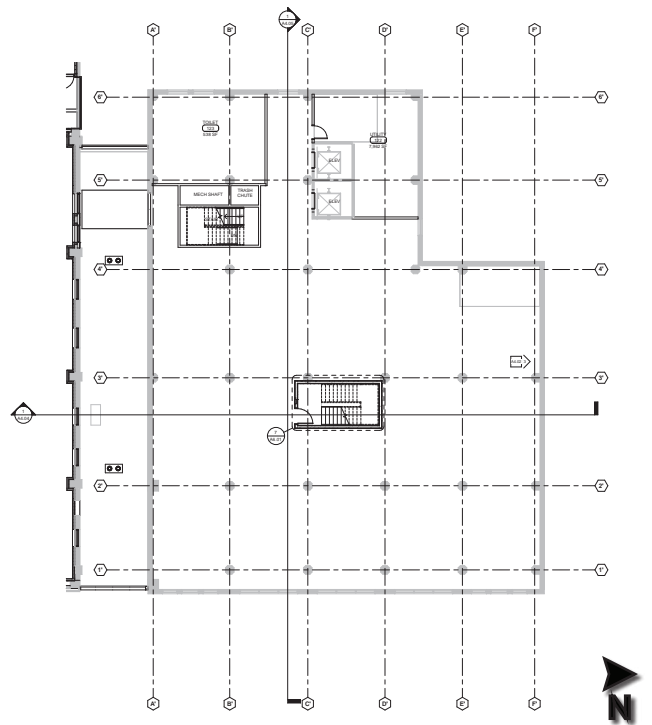

FLOOR PLANS

7th Floor

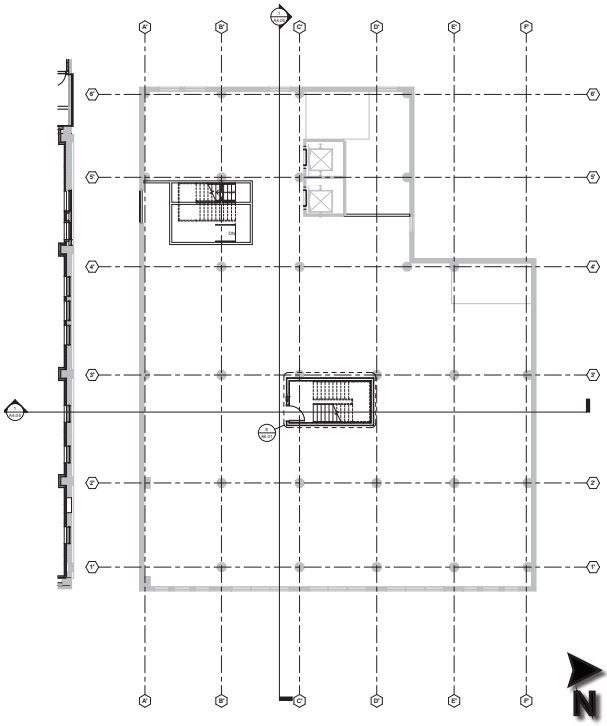

8th Floor

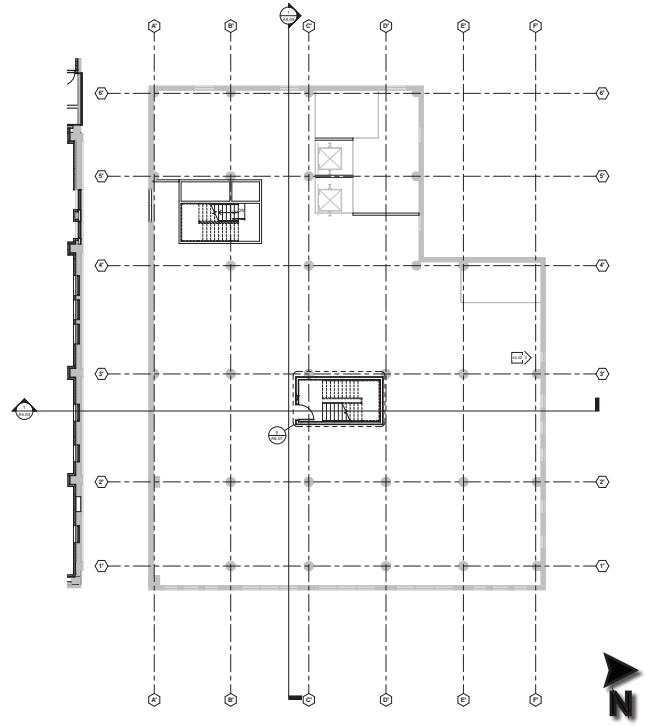

9th Floor

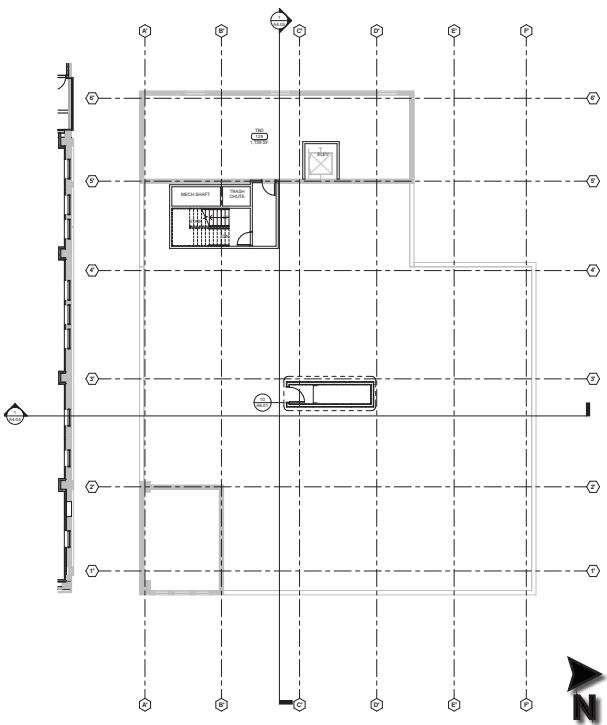

10th Floor

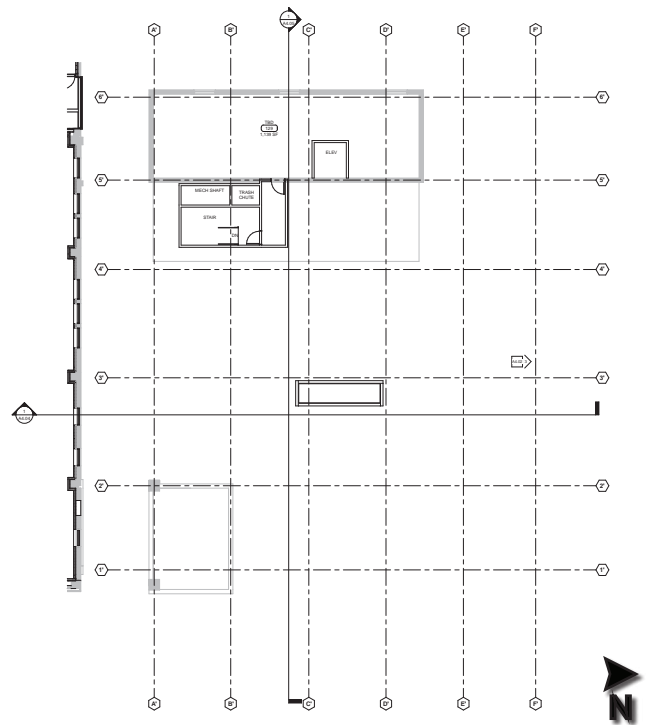

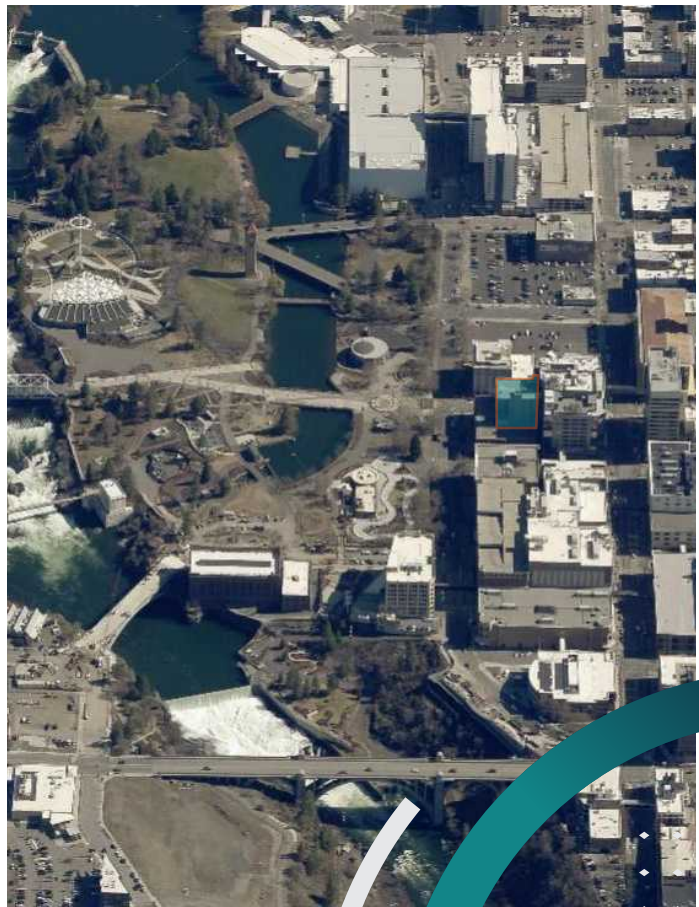
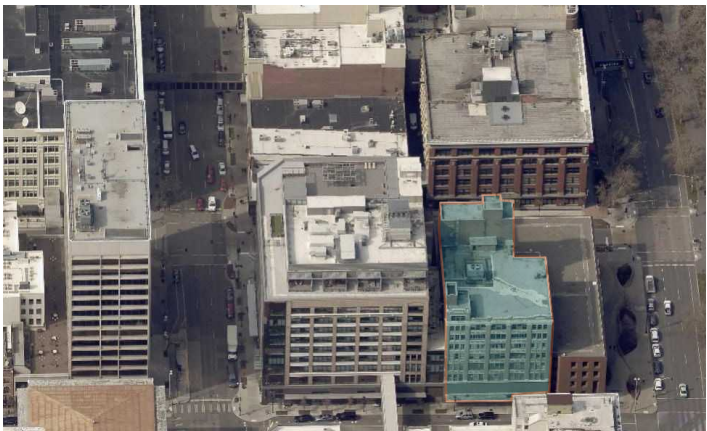

PROPERTY FOR SALE

THE WRAIGHT BUILDING

233 NORTH HOWARD STREET, SPOKANE, WA

CONTACT US

RYAN BRUNETTE

Associate

+1 206 292 6099

ryan.brunette@cbre.com

STEVE BRUNETTE

Senior Vice President

+1 206 292 6007

steve.brunette@cbre.com

CBRE, INC.

1420 5th Avenue

Suite 3800

Seattle, WA 98101

CBRE

© 2024 CBRE, Inc. All rights reserved. This information has been obtained from sources believed reliable, but has not been verified for accuracy or completeness. You should conduct a careful, independent investigation of the property and verify all information. Any reliance on this information is solely at your own risk. CBRE and the CBRE logo are service marks of CBRE, Inc. All other marks displayed on this document are the property of their respective owners, and the use of such logos does not imply any affiliation with or endorsement of CBRE. Photos herein are the property of their respective owners. Use of these images without the express written consent of the owner is prohibited. 1.7.25 CH